



Strategy for Avoiding and Reducing Micropollutants of Diffuse Origin, Based on the Case Study of Plant Protection Products

Synthesis Report

Internationale
Kommission zum
Schutz des Rheins

Commission
Internationale
pour la Protection
du Rhin

Internationale
Commissie ter
Bescherming
van de Rijn

Report No. 240

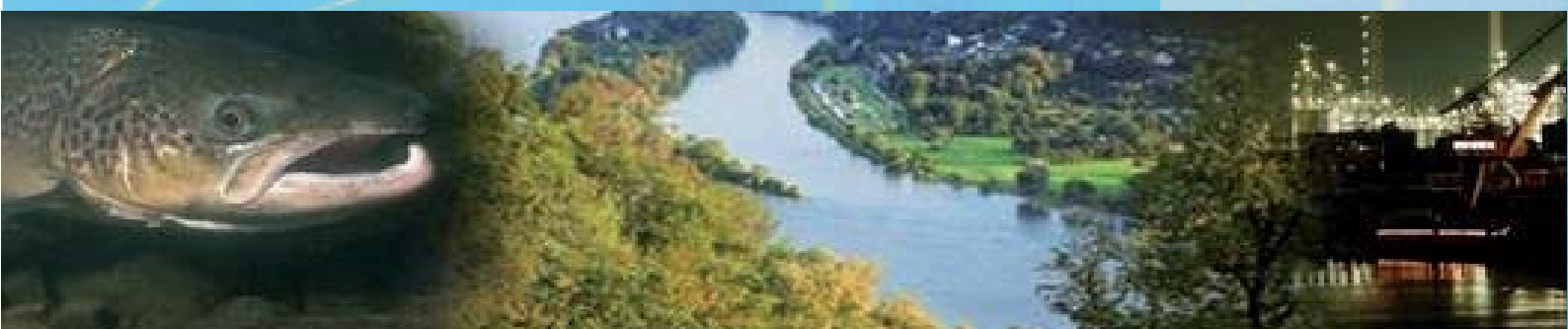

Imprint**Publisher:**

International Commission for the Protection of the Rhine (ICPR)
Kaiserin-Augusta-Anlagen 15, D 56068 Koblenz
P.O. box 20 02 53, D 56002 Koblenz
Telephone +49-(0)261-94252-0, Fax +49-(0)261-94252-52
E-mail: sekretariat@iksr.de
www.iksr.org

ISBN 978-3-946501-06-0
© IKSr-CIPR-ICBR 2017

Contents

1. Introduction.....	2
1.1 What are the diffuse types of influx of micropollutants and their sources, which substances/classes can typically be expected, and to what effect?	2
1.2 The case study of plant protection products	3
2. Methodology	5
2.1 Areas of application	7
2.1.1 Applications in agricultural areas	7
2.1.2 Application in non-agricultural areas	7
2.2 Influx pathways	7
2.2.1 Influx pathways from agricultural areas.....	7
2.2.2 Influx pathways from non-agricultural areas	9
2.3 Method for determining relevant influx pathways	10
3. Analysis of substance-specific influx pathways.....	11
4. Reduction measures.....	15
4.1 European level.....	15
4.2 ICPR Programme for the Sustainable Development of the Rhine (Rhine 2020)	19
4.3 National level.....	20
4.4 Pilot projects	27
5. Conclusion	27
5.1 Potential measures for reducing diffuse influxes of plant protection products	27
5.2 Diffuse influxes of other micropollutants.....	30
Appendix 1 Substance-Specific Influx Paths per Country in the Rhine Catchment Area ..	31
Appendix 2 National Measures and Projects	51

1. Introduction

Within the framework of the ICPR, a strategy was developed regarding micropollutants from urban and industrial wastewater, and a report on the integrated assessment and measures aimed at reducing point-specific influxes was compiled (among other documents)¹. Groups of substances were selected from among the wide variety of chemical substances, for which — with the help of indicator substances — the consumption and application rates, influx pathways into bodies of water, measurement data from surface waters, groundwater and drinking water as well as quality criteria and potential measures were recorded and summarised, within evaluation reports. Based on this data, the most efficient measures were presented for each group of substances. This entails a broad spectrum of important measures at source (e.g. approvals for substances, restrictions of use) as well as technical measures in wastewater treatment plants.

Micropollutants may also enter bodies of water via diffuse types of influx. Using plant protection products as a case study, this report formulates a strategy aimed at avoiding and reducing micropollutants of diffuse origin, comparable to the strategy regarding micropollutants for other groups of substances.

1.1 What are the diffuse types of influx of micropollutants and their sources, which substances/classes can typically be expected, and to what effect?

For the most part, the diffuse influxes of micropollutants comprise extensive influxes of substances that are not precisely localisable, and which generally enter bodies of water in an arbitrary manner. In addition to "point sources", from wastewater treatment plants and industrial plants, diffuse influxes originating from agriculture, traffic emissions or settlements/industry lead to the significant pollution of water bodies and groundwater. Substances such as nutrients (phosphorous and nitrogen compounds), plant protection products, biocides, heavy metals, PAHs and other organic micropollutants enter bodies of water via diffuse pathways. They penetrate surface waters via the air (atmospheric deposition), rainwater run-off (drift, surface run-off and macropores in drainage systems), and through soil erosion or leaching.

Nutrients which are largely of agricultural origin may lead to overfertilisation (eutrophication) of water bodies and the sea. The present report focuses on diffuse influxes of micropollutants, in particular of plant protection products; it does not deal with nutrient influx. Other influxes of diffuse substances may exceed quality criteria for surface waters, which are derived from ecotoxicological standards, or the precautionary quality criteria for groundwater. These substances are not only of agricultural origin. The substance influx may originate partly from industry, or from the use of these substances in private households and gardens, in urban areas, business and traffic-heavy areas or from landfill sites or contaminated sites or the atmospheric deposition of substances dispersed into the air.

The local and regional environmental burdens on smaller surface waters and groundwater may lead to the short-term, significant and even lasting pollution of aquatic ecosystems. Following the flow path, the pollution may reach tributaries and the main stream of the Rhine. As river water is also used for drinking water abstraction, micropollutants may result in an increased effort outlay in terms of drinking water treatment. Micropollutants of diffuse origin may therefore pose a risk to the ecology of rivers, in particular in smaller water bodies, as well as to drinking water production. In particular, bio-accumulating, persistent substances may be consumed directly (e.g. via drinking water) or via the food chain. This also concerns human beings.

¹ [ICPR Technical Report No. 203](#)

1.2 The case study of plant protection products

This report utilises the case study of a group of plant protection products for the closer analysis of further substances or groups of substances of diffuse origin. Diffuse pollution due to plant protection products is therefore examined more closely, typical influx pathways are identified, different measures in the Rhine catchment area are compared and approaches identified that may also be applied to other substances and groups of substances transported via diffuse pathways. This synthesis report should serve to identify the possibilities for a joint, coordinated approach for reducing levels of substances of diffuse origin.

Plant protection products are used worldwide; European countries represent significant consumers of these products. Agriculture is by far the most significant area of application of plant protection products. Plant protection products also have applications outside of the agricultural sector, e.g. on sealed surfaces, in private gardens, on public municipal grassy areas, sports grounds, along roads or as weed killers along railway lines.

A prerequisite for the application of these products in an EU member state is that an active ingredient figures in the positive list of the European Plant Protection Products Regulation (Regulation (EC) no. 1107/2009). Subsequently, producers can apply for an approval for plant protection products containing this active ingredient. In terms of a national approval for the products, specific evaluations may be taken into account and a certain use of the product may be limited or excluded.

With regard to the Water Framework Directive (WFD - Directive 2000/60/EC), Environmental Quality Standards (EQS) apply at EU level for priority (hazardous) substances in surface waters. Furthermore, substances relevant to the Rhine, and on a national level, within the framework of the WFD, are identified as river basin-specific pollutants, for which EQS are also established. Plant protection products figure on both substance lists. The Management Plan 2015² for the Rhine (part A) shows that the EQS are not yet comprehensively heeded. In particular, waves of pollutants containing plant protection products occur, which also entail values for drinking water which are in excess of the directive relating to "water intended for human consumption" (Directive 98/83/EC) (ICPR report no. 220).

A common trigger for impact loads due to diffuse influxes into surface waters is heavy rainfall, which, due to surface run-off, drainage and erosion leads to peak loads in surface waters (loads / concentrations) and therefore within the framework of the Rhine warning and alarm system regularly prompts alert notifications (see ICPR Technical Reports nos. 220, 217, 205, 197, 191, and 184). The ICPR reports nos. 211, 150 and 135 also cover relevant isoproturon influxes, which have been observed for several years. Peak loads are often larger in smaller, regional surface water bodies and occur, limited in a localised manner, in groundwater. In metrological terms, the highly dynamic nature of rain discharge means that diffuse pollution in small rivers is very difficult to quantify representatively, in contrast to larger rivers. As, in smaller waters, these peak loads only occur for a short time, they can only be detected by flexible monitoring programmes with a high measuring frequency, immediately after heavy rainfall. In larger rivers, peak loads are lessened due to dilution, and averaged. The dilution and dispersion of substances in larger rivers leads to less extreme, but longer-lasting pollution, which is detected by usually comprehensive monitoring, thus tending to give a representative picture.

In addition to the approved plant protection products that are detected in surface waters, those that have been on the banned substance list for years (decomposition products and metabolites of plant protection products) are also still present. Apart from illegal applications, which cannot be ruled out, in many cases, this indicates historical pollution. Due to long retention times, groundwater may still be polluted and, if connections to surface waters exist, these surface waters may be contaminated anew (e.g. atrazine).

² [ICPR Management Plan 2015](#)

Certain substances may also be adsorbed into sediment (e.g. HCH, DDT, heavy metals), and surface waters may be polluted anew due to the leaching or stirring up (remobilisation) of sediments polluted by these substances and the erosion of polluted soil.

Due to the fact that there are innumerable active ingredients used in plant protection products in the Rhine catchment, a selection was made for this summary report. Active ingredients and metabolites integrated into the "Rhine 2011" list of substances (ICPR report no. 189) and the most frequent substances detected in the Rhine and its main tributaries were selected as indicator substances, through an assessment by experts. Further criteria consisted of values in excess of the environmental quality standards and the drinking water standards. In this way, all countries in the Rhine catchment are jointly responsible for these substances.

The following substances were selected:

- Bentazone
- Carbendazim (also as degradation product of the plant protection product thiophanate-methyl)
- Chlorotolurone
- Desethylatrazine (degradation product of the product atrazine)
- Diurone
- Glyphosate and its degradation product AMPA
- Isoproturon
- Mecoprop/Mecoprop-p

Almost all of the indicator substances selected for this report are herbicides. Often, herbicides are used in higher concentrations than other plant protection products, meaning that the risk of higher concentrations in large water systems increases. Other plant protection products such as insecticides, which may be hazardous at much lower concentrations, occur in particular in regional water systems.

The substances carbendazim and mecoprop have also been assessed in the "Evaluation report on biocidal products and anti-corrosive agents" (ICPR report no. 183) as these substances, along with other diverse plant protection products (e.g. diurone) are also used as biocides e.g. for protecting buildings (e. g. carbendazim as fungicide in silicone sealants and mecoprop in bitumen for flat roof sealing systems). Other plant protection product active ingredients (none of the agents selected here) may also be used in livestock breeding (e.g. as antiparasitic agents, fungicides or disinfectants), depending on their spectrum of efficacy and level of approval. The use of some active ingredients as plant protection products and as biocides explains (amongst other reasons) why some plant protection products which are now no longer permitted, continue to be relevant for water pollution.

2. Methodology

The methodology described here for plant protection products forms the basis for determining the most relevant influx pathways for further groups of substances. With this level of detail applied, the ICPR is able to pinpoint problems concerning diffuse influxes and their sources in a more precise manner, outlining these for stakeholders, so that measures may be taken.

In order to develop a general method for determining the most relevant, diffuse influx pathways, the influx pathway scheme used for developing a strategy for dealing with micropollutants from urban and industrial settlements³ has been further detailed and differentiated for the group of plant protection products (see Figure 1). Above all, the diffuse sources of plant protection products were divided into agricultural and non-agricultural activities, which differ in many ways when it comes to influx pathways, applications and users.

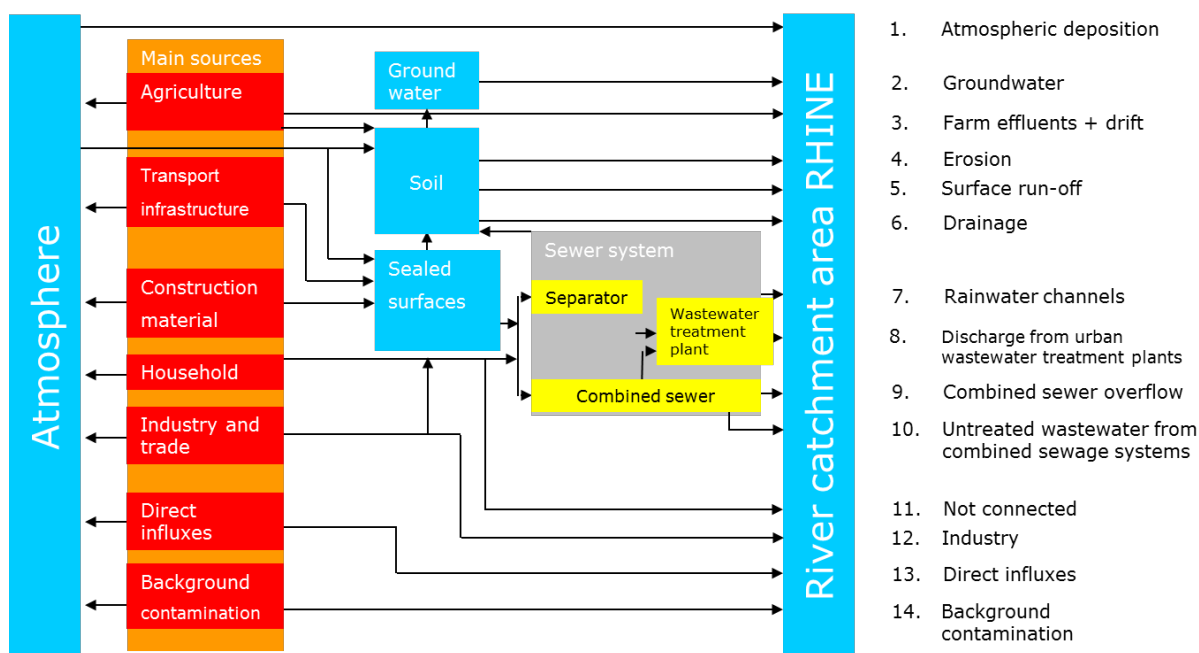

Figure 1a: Scheme showing influx pathways into surface waters, according to area of application: general scheme for influx pathways of micropollutants³.

³ [ICPR Technical Report no. 181](#), [ICPR Technical Report no. 203](#)

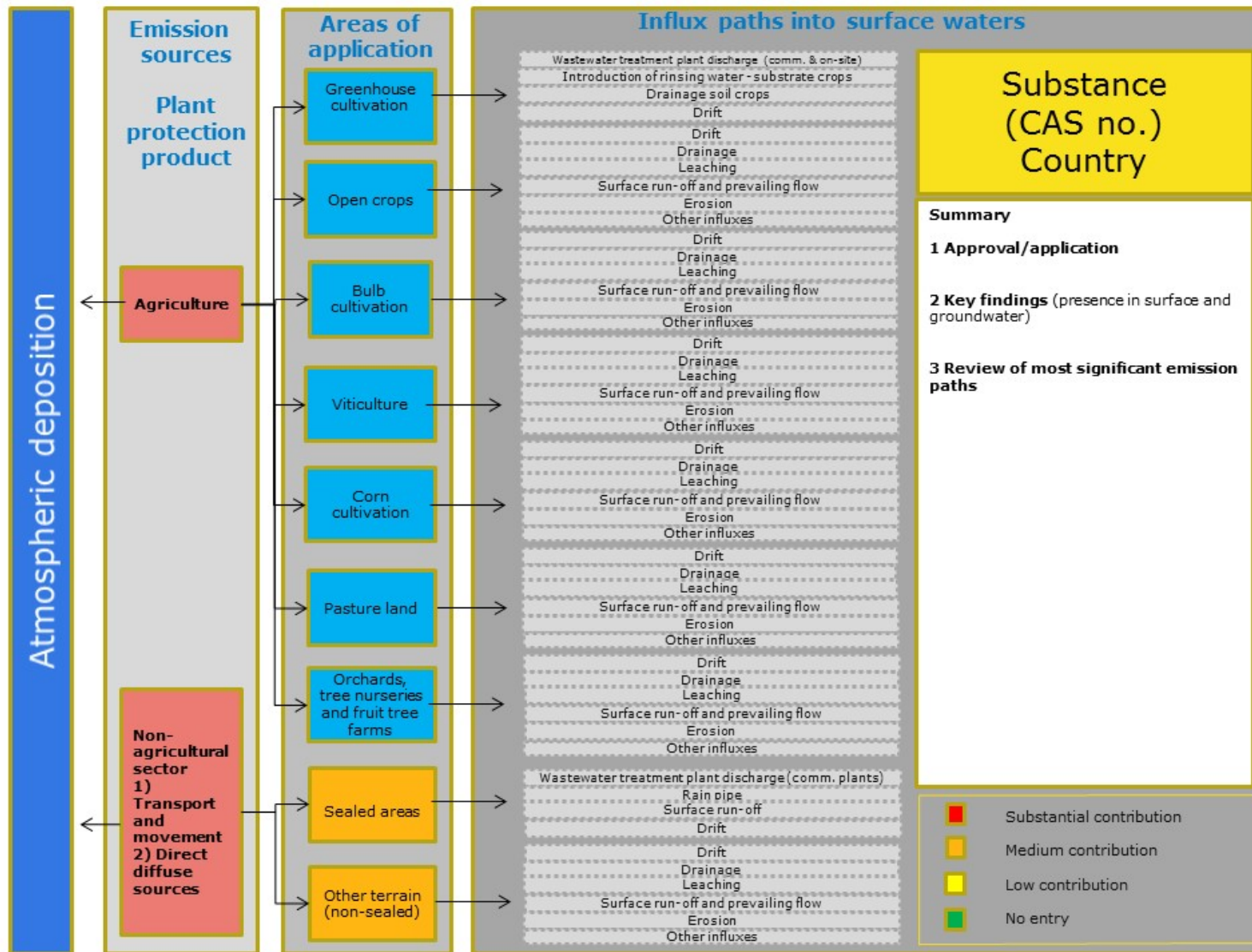

Figure 1b: Scheme of influx pathways in surface waters, according to area of application: influx pathway scheme adjusted for plant protection products.

2.1 Areas of application

For both sources of influx of plant protection products (agricultural and non-agricultural sectors) areas of application are established for further classification and subdivision.

2.1.1 Applications in agricultural areas

The areas of application within agriculture are split into groups of comparable crops and types of use. In agriculture, the focus is on the following 7 areas of application:

1. Greenhouse cultivation: Greenhouse crops must be divided into two groups: substrate crops and soil-grown crops. Areas of interest here are the cultivation of fruit and vegetables in greenhouses, as well as that of flowers and floricultural plants. The cultivation of fruit in boxes and baskets, as well as in pots and containers behind glass is also reviewed here.
2. Open crops: all arable crops such as grains, potatoes, carrots, turnips and other types of vegetables. This includes crops grown on smaller surfaces, such as onions and herbs, e.g. parsley and chives;
3. cultivation of bulbs: all bulb cultivation for floricultural plants in the soil, such as tulips and lilies;
4. viticulture: the growing of grapes for wine production as well as grapes for consumer purposes is also relevant here;
5. corn cultivation: extensive cultivation of feed corn and maize for energy production, as well as maize for human consumption (to a lesser extent);
6. grassland: the application of plant protection products on pastures and fields mostly used for cattle breeding;
7. orchards, tree nurseries and fruit production (including Christmas tree plantations): trees and trellised fruit, where in terms of spraying, both upwards and sideways techniques are required. These techniques often entail their own unique dispersal patterns, which strongly differ from those of downward pointing spraying techniques, which are used for open crops and bulb cultivation. Treatment measures in forestry follow yet another dispersal pattern, but are nevertheless included under this category.

2.1.2 Application in non-agricultural areas

In the non-agricultural sector, two fields of application are the focus here:

1. sealed surfaces (pavements, streets and squares from which rainwater drains into surface waters and/or the sewer system);
2. unsealed surfaces (other non-agricultural surfaces such as parks, grassy areas along streets and roads, sports grounds and railway lines).

In both areas, professional applications (horticulturists, contractors and suppliers; road administration/rail operation) as well as private applications (gardens, allotment gardens and grassy areas adjacent to houses) are possible.

2.2 Influx pathways

For each area of application, the most significant influx pathways for plant protection products into bodies of water are described below (in bold).

2.2.1 Influx pathways from agricultural areas

Figure 2 illustrates the influx pathways from agricultural areas.

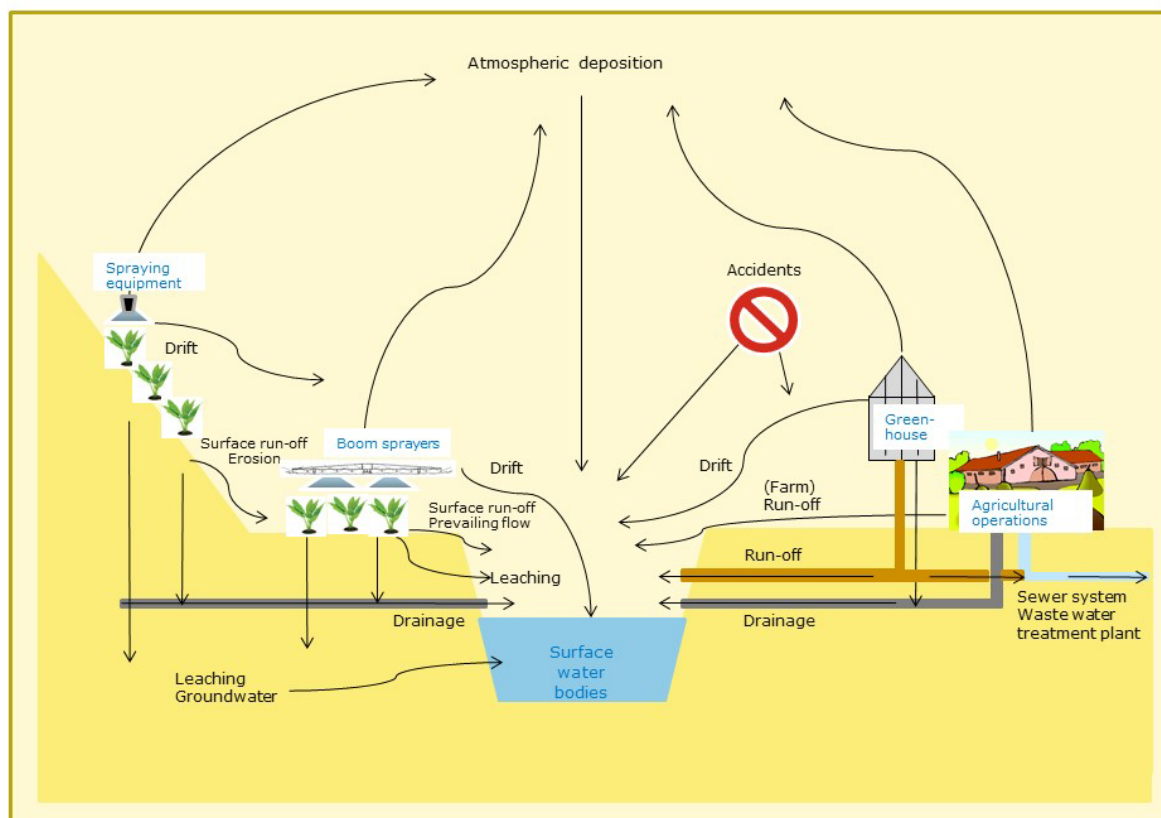

Figure 2: Diagram of the influx pathways of plant protection products of agricultural origin

The pathways represented in Figure 2 are described below:

- In greenhouse cultivation, the influx pathways of substrate crops differ from those of soil crops. In the case of substrate crops, the water cycle is almost completely closed. Nutrients, as well as plant protection products, are fed in via the process water. Due to the closed cycle, substances secreted into the process water reach concentrations detrimental to cultivation, meaning that **drainage** is often required. The discharge may contain considerable levels of plant protection products. In principle this effluent is discharged into the **sewer system**, unless this is not possible in practice. In this scenario, in the Netherlands, the wastewater may be discharged into surface waters until 2018⁴. As regards soil-grown crops, plant protection products are sprayed or sprinkled, which may lead to **drift**⁵. The soil is drained in order to remove surplus water. This **drained water**⁶ may therefore contain plant protection products, and an influx into the groundwater cannot be entirely ruled out. Drainage water and groundwater may enter surface waters.
- In open crops, but also in bulb cultivation, corn cultivation and on pasture land, a downward spraying technique is applied. In this way, plant protection products may enter surface waters via various pathways. A distinction is made between: **drift**,

⁴ From 2018 onwards, it will be compulsory that all wastewater from greenhouse cultivation must be treated in such a way that at least 95% of the plant protection products are removed via the sewer system or surface water, prior to discharge into a wastewater treatment plant.

⁵ The drifting of small drops of sprayed liquid during spraying.

⁶ Discharge of excess groundwater and water seepage from the ground surface via perforated pipes under the crops. In terms of the influx of plant protection products into surface waters, it is above all the rapid seepage through coarse pores (macropores) in drainage pipes which is relevant here.

drainage, leaching⁷, surface run-off⁸ as well as **prevailing flow⁹** and **erosion¹⁰**.

In principle, atmospheric deposition also plays a role in terms of influx into surface waters. With regard to loads, atmospheric deposition may be a significant source of discharge, but this pathway does not account for higher concentration peaks in surface waters¹¹. In addition, **further discharges** in the form of concentrated emissions into the environment are taken into account. This may relate to accidents, but also influxes into the surface water due to poor agricultural practices: e.g. negligent handling of packaging with plant protection product residues; the introduction of rinsing/cleaning water or spray residue into the sewer system, or directly into a surface water body.

- In the case of upward and sideward spraying techniques, for example in orchards, tree nurseries and fruit tree farms, but also in viticulture, the influx paths are comparable (**drift, drainage, leaching, surface run-off and prevailing flow, erosion and other influxes**), however due to the differing techniques, differently distributed. These techniques involve significantly more pronounced influxes due to drift, in comparison to downward spraying techniques, which currently reduce drift and retain the plant protection products on the plot as far as possible.

2.2.2 Influx pathways from non-agricultural areas

In non-agricultural areas, sealed and non-sealed areas (other terrain) are affected:

- On sealed areas, selected spray techniques can still be used in a number of member states for combating weeds, in order to only spray those areas in which the weeds grow. Although bans are being implemented or prepared in all member states to prohibit the use of plant protection products on sealed surfaces, they are currently still being used. Areas which cannot be reached by machines are often treated in a targeted manner with a spray lance. In principle, only the use of herbicides is affected here. The influx path into the body of water is location-dependent: either directly through **surface run-off** from sealed surfaces or, during spraying, via **drift** into the surface water or via **rain pipes**. In the case of a combined sewer system, this water is introduced into a wastewater treatment plant. The discharges into bodies of water via wastewater treatment plant drainage are highly dependent on the substance, but also on the efficiency of the wastewater treatment plant that the water has passed through.
- In the case of use on other terrain (including all green areas, golf courses or other sports facilities, parks, private gardens, green belts along traffic routes and railway lines), this is not necessarily just a case of the targeted application of a spray by hand. In individual cases it may also be a question of extensive use in terms of precautionary applications (e.g. at golf courses, lawn areas in "well-maintained" facilities). The influx pathways for other terrain do not differ to those of open crops (**drift, drainage, leaching, surface run-off and prevailing flow, erosion and other influxes**), but the relevance of the influx pathways can be differently distributed.

⁷ E.g. rainwater that flows/seeps into the groundwater, and then via the groundwater reaches the surface water.

⁸ As soon as the soil can no longer absorb further rainwater, surface run-off occurs. The water that is rapidly discharged on the soil surface may transport substances from the agricultural crop land directly into the body of water, or via a bypass route. Bypass routes include, for example, shafts for road drainage, or inspection shafts in the drainage system. Surface run-off is often coupled with erosion, which can lead to additional substance influxes.

⁹ Flow via flow paths in the soil, through cracks or micropores.

¹⁰ The flooding of solid particles into the surface water, cf. surface run-off.

¹¹ In the greater Paris area, measurable pesticide levels in the air from applications in agriculture outside urban areas have already been demonstrated: Observatoire des Résidus des Pesticides, 2010; Aiparif, Lettre n° 29, 2007; Aiparif, Evaluation des concentrations en pesticides dans l'air ambiant francilien, 2007.

2.3 Method for determining relevant influx pathways

The influx pathways can be classified pragmatically according to their significance for influxes into bodies of water, with the colours green (no entry), yellow (low contribution), orange (medium contribution) and red (significant contribution) (see Figure 1 and Table 1). The knowledge required for determining the influx pathway and the assessment of its extent can be based on expert judgement, general knowledge as well as the physico-chemical properties of the substance concerned, as there is often no specific measurement data directed towards the investigation of the relevant influx pathways, and representative estimates of loads are often impossible. In the present approach, it is therefore not possible to precisely quantify the loads of substances and emissions in the member states. Instead, the significance of influx pathways for each area of application and indicator substance is assessed by the member states for their particular area, based on expert judgement.

The result is an overview for each substance with relevant fields of application and influx pathways. For an overview for each ICPR member state, see Appendix 1.

3. Analysis of substance-specific influx pathways

Based on the classification of the current significance of the diffuse influx pathways according to the area of application and the ICPR member state (see Appendix 1), an overview of the Rhine catchment area can be created for each indicator substance. The four classification categories (none, low, medium and substantial contribution) are assigned the values 0 to 3 for each state, and these values are then totalled for each area of application, influx pathway and indicator substance. The relative contribution of an influx pathway to water pollution per indicator substance is presented based on this sum (Table 1). Future policy decisions, e.g. regarding the authorisation of substances, and/or measures, may alter this estimation.

Table 1: Summary table of the relevant influx points in the Rhine catchment area

Application	Influx pathway	Overall assessment*							
		Name of substance							
		Bentazone	Carben- dazim ¹²	Chlor- toluron	Desethy- latriazine	Diuron ¹²	Glypho- sate	Iso- proturon	Mecoprop- p / Mecoprop
Agriculture									
Greenhouse cultivation	Drift	0	0	0	0	0	0	0	0
	Wastewater	0	0	0	0	0	0	0	0
	Introduction of rinsing water								
	Substrate crops	0	0	0	0	0	0	0	0
	Drainage soil crops	0	0	0	0	0	0	0	0
Open crops (e.g. arable crops)	Drift	5	1	3	0	0	6	5	5
	Drainage	13	3	8	0	0	15	13	14
	Leaching	11	1	5	0	0	9	12	10
	Surface run-off and prevailing flow	11	3	8	0	0	11	14	13
	Erosion	5	1	3	0	0	9	6	6
	Other influxes	6	2	4	0	0	6	6	5
Bulb cultivation	Drift	0	0	0	0	0	3	0	0
	Drainage	0	0	0	0	0	4	0	0
	Leaching	0	0	0	0	0	4	0	0
	Surface run-off and prevailing flow	0	0	0	0	0	1	0	0
	Erosion	0	0	0	0	0	1	0	0

¹² Approval as a plant protection product in only one ICPR member state

Application	Influx pathway	Overall assessment*							
		Name of substance							
		Bentazone	Carben-dazim ¹²	Chlor-toluron	Desethy-latrazine	Diuron ¹²	Glypho-sate	Iso-proturon	Mecoprop -p / Mecoprop
	Other influxes	0	0	0	0	0	1	0	0
Viticulture	Drift	0	2	0	0	2	5	0	0
	Drainage	0	3	0	0	3	8	0	0
	Leaching	0	1	0	0	1	7	0	0
	Surface run-off and prevailing flow	0	3	0	0	3	7	0	0
	Erosion	0	1	0	0	1	8	0	0
	Other influxes	0	2	0	0	2	4	0	0
Corn cultivation	Drift	4	0	0	0	0	5	0	1
	Drainage	10	0	0	1	0	12	0	1
	Leaching	11	0	0	6	0	6	0	1
	Surface run-off and prevailing flow	10	0	0	1	0	8	0	1
	Erosion	5	0	0	2	0	8	0	1
	Other influxes	4	0	0	0	0	5	0	1
Pasture land	Drift	3	0	0	0	0	5	0	1
	Drainage	8	0	0	0	0	11	0	3
	Leaching	5	0	0	0	0	6	0	1
	Surface run-off and prevailing flow	6	0	0	0	0	6	0	1
	Erosion	3	0	0	0	0	8	0	0
	Other influxes	4	0	0	0	0	4	0	0
Orchards, tree nurseries and fruit tree farms (including Christmas tree farms)	Drift	0	2	0	0	2	7	0	4
	Drainage	0	3	0	0	3	13	0	4
	Leaching	0	1	0	0	1	9	0	3
	Surface run-off and prevailing flow	0	3	0	0	3	10	0	5
	Erosion	0	1	0	0	1	7	0	1
	Other influxes	0	2	0	0	2	6	0	1
Non-agricultural area									
Sealed areas	Drift	0	0	0	0	0	3	0	1
	Wastewater	0	3	0	0	8	9	2	4
	Rain pipes	0	3	0	0	8	10	1	3

Application	Influx pathway	Overall assessment*							
		Name of substance							
		Bentazone	Carben-dazim ¹²	Chlor-toluron	Desethy-latrazine	Diuron ¹²	Glypho-sate	Iso-proturon	Mecoprop-p / Mecoprop
	Surface run-off	0	1	0	0	3	8	0	2
Other terrain (non-sealed)	Drift	1	0	0	0	0	4	0	4
	Drainage	3	0	0	0	0	4	0	7
	Leaching	1	0	0	0	1	6	0	4
	Surface run-off and prevailing flow	3	0	0	0	0	6	0	6
	Erosion	1	0	0	0	0	6	0	3
	Other influxes	3	0	0	0	0	4	0	4

* The overall assessment is based on the assessment of influx paths by CH, DE, FR, LU and NL. The assessments are based on qualitative (expert judgements) and not on quantitative assessments.

Key

Points per state	Evaluation	Total points
0	No contribution	0-2
1	Low contribution	3-7
2	Medium contribution	8-12
3	Significant contribution	13-15

Table 1 shows that the selected plant protection products contribute differently to water pollution in the respective areas of application. In terms of agricultural use, greenhouse cultivation, for example, is not a contributing factor, as the selected indicator substances are not relevant for these crops. In the above evaluation, the influx from open crops is the most dominant. In addition to individual areas of application, a clear distinction is also made between agricultural and non-agricultural sectors. In non-agricultural sectors, active ingredients, which are also used as biocides, are allocated a higher relative contribution. A general statement regarding the contribution to water pollution of certain areas of application cannot be derived from the scheme.

Of the plant protection products selected here, glyphosate followed by bentazone, has the widest application. The relevance of the individual plant protection product active ingredients is influenced by the approval situation here. For example, diuron and carbendazim as plant protection products are permitted in the ICPR member states only in Switzerland. Only partially approved plant protection products may nevertheless still be relevant to the whole Rhine catchment area, as they are still present in bodies of water due to their application as a biocide, contamination from inherited waste sites or occurrences of metabolites or degradation products. It should also be noted in this context that influx paths that are denoted as having a low contributing factor in Table 1 can nevertheless be the most relevant influx pathways of this substance, however this is not apparent when considering the approval criteria. This is the case, for example, for diuron (cf. also Appendix 1).

Different influx pathways can be relevant depending on the area of application. In the overview it should not be forgotten that wastewater treatment plants are classified under the influx pathway "other influxes", unless otherwise specified. Wastewater treatment plants can represent a significant source, e.g. due to the cleaning of spraying equipment. This explains the categorisation "medium contribution" of the influx path "other influxes" for some fields of application. On the basis of the present qualitative expert judgement, the most relevant influx paths for the plant protection products selected here (mainly herbicides) and area of application, appear to be drainage, leaching, surface run-off and prevailing flow. This does not mean, however, that the other influx paths are irrelevant. The drifting of approved plant protection products in open crops can therefore also still play a role in smaller surface waters located near to the area of application. The relative significance in the Rhine main stream is lower, however, due to dilution. It is possible that the significant level of attention given to drift-reducing measures in recent decades has contributed to the lower significance of drift.

4. Reduction measures

This section begins with a description of the measures at a European level (Section 4.1). Section 4.2 deals with the ICPR programme "Rhine 2020" with regard to plant protection products. Sections 4.3 and 4.4 describe measures implemented by the member states of the ICPR in order to reduce the influx of plant protection products into ground and surface waters.

4.1 European level

The seventh Environment Action Programme (EAP) "Living well, within the limits of our planet" forms the EU Environmental Policy Guidelines up to 2020,¹³ and the focus for the period 2014-2020 for stimulating sustainable agriculture and new agricultural techniques lies within the framework of the joint Common Agricultural Policy (CAP)¹⁴. In addition, four essential elements can be distinguished: 1) the Water Framework Directive, 2) approvals, 3) the Directive 2009/128/EC regarding a framework for community action for the sustainable use of pesticides and 4) an Action Plan for the future of organic farming in the European Union.

1) Water Framework Directive

In 2000, the European Parliament and the European Council adopted the Water Framework Directive, which aims to achieve comprehensive water protection in the European river basins. Among other matters, EQS were defined for specific, so-called priority (hazardous) substances. If the EQS are exceeded, reduction measures, and ultimately compliance with the EQS must be adopted. The priority substances also include plant protection products and, as the Management Plan 2015 for the Rhine (Part A) shows, the EQS has not yet been complied with in all areas. In particular, peak loads with plant protection products are detected. In recent years, for example, reports have demonstrated increased isoproturon concentrations via the Rhine warning and alarm plan, which have led to the suspension or restriction of water abstraction from the Rhine for drinking water purification purposes. There is thus a need for measures to be taken, to further reduce the influx of plant protection products. It should also be noted that the list of priority substances and their respective EQS are regularly revised at EU level. However, plant protection products also play a major role in the substance lists of river basin-specific pollutants, which also underlines the need for action in this area.

2) Approvals

Before a plant protection product active ingredient can be used in a European country, the substance must be approved within a collaborative EU process. Following the positive outcome of the approval procedure, the substance (based entirely on its safe application) is placed on the approval list of the EU Plant Protection Products Regulation (Regulation (EC) 1107/2009, previously EU Harmonisation Directive 91/414/EEC). Subsequently, manufacturers in the member states can apply to use plant protection products that contain this active ingredient within the framework of zonal application procedures. For the national registration of substances, an application may be authorised under certain specific conditions (quantities used, crops, regional regulations, for example no use or the use of smaller quantities in water protection areas, etc.).

In Switzerland, the approval procedure takes place according to the Ordinance on Plant Protection Products dated May 12th 2010 (PSMV, SR 916.161), in which major segments of EU law were adopted. Only plant protection products that contain active substances listed in Appendix 1 of the PSMV may be placed on the market. In contrast to the EU member states, the same authority (the Federal Office for Agriculture) is responsible for both the approval of active ingredients in plant protection products as well as for the plant protection products themselves.

¹³ Resolution No. 1386/2013/EU of the European Parliament and of the Council dated 20th November 2013

¹⁴ The larger majority of the CAP legislation is governed by Regulations 1305/2013, 1306/2013, 1307/2013 and 1308/2013.

3) Directive 2009/128/EC

The directive 2009/128/EC regarding a community action framework for the sustainable use of pesticides, which was adopted in 2009, obliges the EU member states to take measures to reduce the impact on both humans and the environment of the pesticides used, to introduce the transition to integrated plant protection, and to promote alternative methods of pest control.

A central working device also prescribed by the directive for member states entails setting up a separate National Action Plan (NAP) as per Article 4 of this directive. In these National Action Plans, the EU member states set specific targets to make the application of pesticides more sustainable. The NAPs must also contain indicators, which can be used to monitor compliance with the targets. The measures contained therein must be evaluated and selected taking into account health-related, social, economic and environmental impact factors. The EU member states were required to establish their NAPs by 14th December 2012, and to include public participation. The plans must be revised and adapted every 5 years. Directive 2009/128/EC states that the EU Commission must review the submitted Action Plans and draw up a report by 14th December 2014. This report is not yet available.

Further obligations of the member states under the directive include:

- the training and continuing education of professional users, distributors and consultants to ensure that information regarding the safe handling of pesticides and spraying equipment is always based on the most current developments;
- when selling to non-professional users, the customer must have access to expert advice;
- information and awareness campaigns must inform people about the risks and correct application of pesticides;
- establishment of a test system for regular checks regarding application systems;
- adoption of clear guidelines regarding the storage and handling of pesticides;
- prohibition of spraying by helicopter or aircraft;
- preference for non-water-hazardous active ingredients and efficient application techniques for reducing drift;
- risk mitigation measures should be considered in order to minimise the risk of contamination outside the application area through drift, drainage and surface run-off. These include the establishment of suitably sized buffer zones for the protection of the aquatic environment, and also the establishment of protected areas for surface waters and groundwater for the extraction of drinking water, in which pesticides cannot be used or stored;
- as comprehensive a renunciation as possible of the use of pesticides on or along roads, railways, in very permeable areas or other infrastructures in the vicinity of surface water or ground water, as well as on sealed surfaces where there is a high risk of leakage into surface waters or sewer systems;
- where necessary, intensify measures in specific protected areas, explicitly also the protected areas as defined by the Water Framework Directive;
- promotion of plant protection with a lower pesticide expenditure, moving towards integrated plant protection.

It is up to the individual member states to decide to what extent these measures are implemented, and which options are ultimately taken into account, but the targets must be achieved.

The relevant National Action Plans are accessible online:

(http://ec.europa.eu/food/plant/pesticides/sustainable_use_pesticides/nap_en)

In Switzerland, the first Action Plan on risk reduction and the sustainable use of plant protection products is currently being prepared. However, legal guidelines comparable to the directive 2009/128/EC are lacking in Switzerland. The Swiss Action Plan was commissioned by the Federal Council, issued on the basis of a needs assessment (postulate 12.3299).

Table 3 in Section 4.3 gives an overview of the national measures per ICCR member state.

4) Action Plan for the future of organic farming in the European Union

In 2004, the EU Commission adopted the first European Action Plan for Organic Food and Farming, to promote and strengthen the organic sector¹⁵. In 2014, the EU Commission adopted a new Action Plan, to support organic farming in the period up to 2020¹⁶. In the last 30 years or so, the number of organic farmers as well as the area of organic farming methods has increased sharply in Europe — from virtually zero to over 11 million hectares (Figure 3). Approx. 90% of this lies within the EU¹⁷. Figure 4 shows the proportion of organically farmed agricultural land in the individual member states in the Rhine catchment area in 2014¹⁸. Here, agricultural areas throughout the country are taken into account, not just the proportion in the Rhine catchment area. Information regarding the organically farmed area of the Rhine catchment — in the countries that lie within the Rhine catchment area — is not (directly) available, except for that relating to Liechtenstein, which is 100% within the Rhine catchment area. Of the countries in the Rhine catchment area, Liechtenstein is well ahead of the rest of the states (also in Europe) with a good 30%, while the Netherlands has the smallest proportion of organic farming areas, with 2.5%.

¹⁵ Communication from the Commission to the Council and the European Parliament on the European Action Plan for Organic Food and Farming, Brussels, 10.06.2004 (COMM(2004) 415 final)

¹⁶ Communication from the Commission to the European Parliament, the Council, the European Economic and Social Committee and the Committee of the Regions - Action Plan for the Future of Organic Production in the European Union, Brussels, 24.3.2014 (COMM(2014) 179 final)

¹⁷ Organic in Europe – Prospects and developments, IFOAM 2016

¹⁸ Meredith, S. and H. Willer, Organic in Europe: Prospects and developments, IFOAM EU Group, Brussels (Belgium), 2014

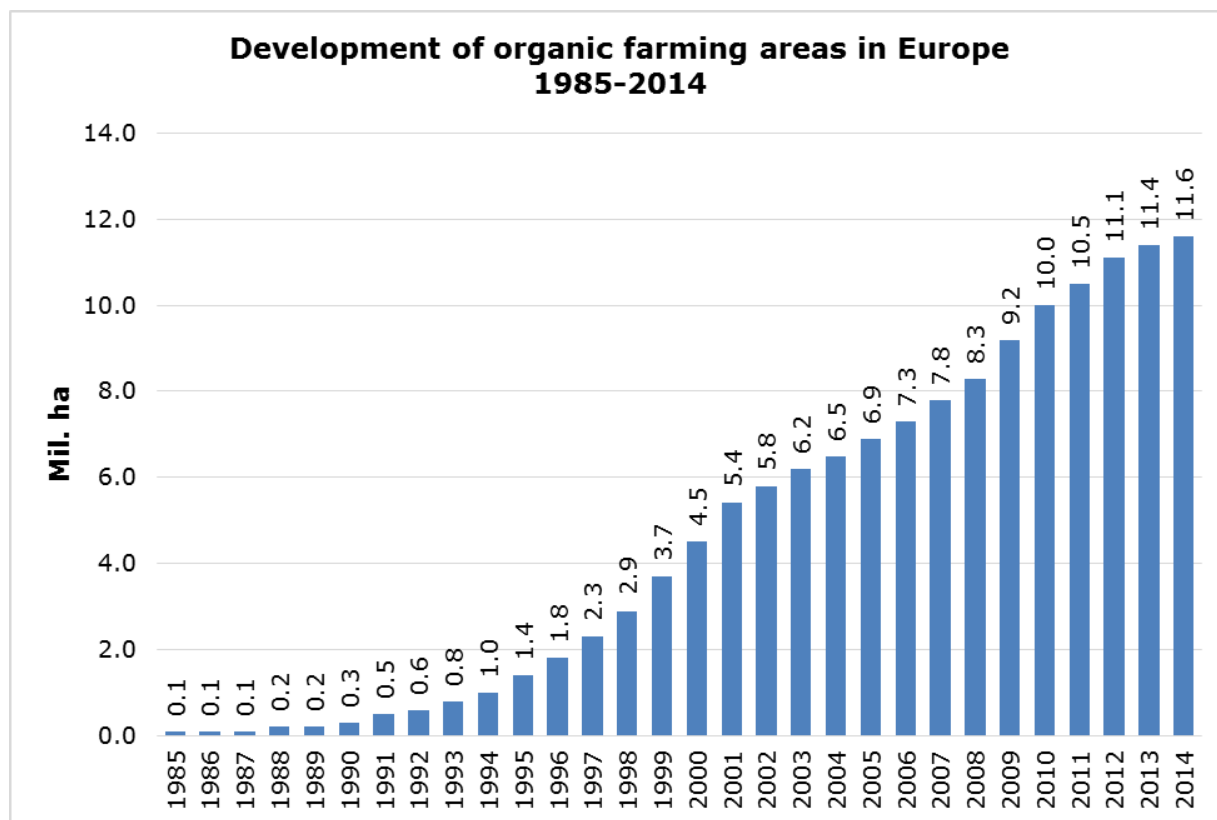

Figure 3: Development of organic farming areas in Europe 1985 to 2014 (Source: Lampkin, Nic, FiBL-AMI Surveys 2006-2016, and OrganicDataNetwork Surveys 2013-2015, based on national data sources and Eurostat)

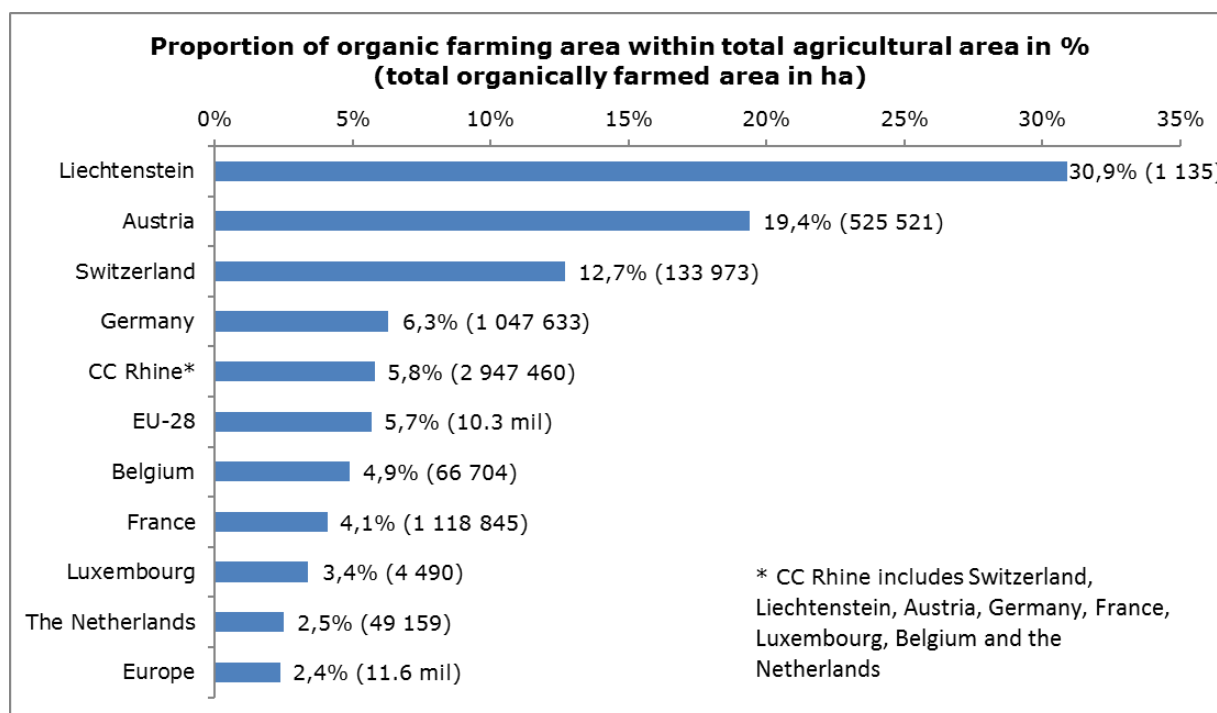

Figure 4: Proportion of organic farming area in total agricultural area in % (total organically farmed area in hectares) (Source: FiBL-AMI survey 2016 based on Eurostat and national data sources)

In addition, as of 2001, the states within the Rhine catchment area have developed Action Plans for the development of organic farming at a national or regional level. The situation is illustrated in Table 2^{18,19}.

Table 2: Overview of the Action Plans implemented in countries in the Rhine catchment area

Country	Time period	Number of previous Action Plans	Implementation of first Action Plan	Target organic farming area within total agricultural area	Target year
AT	2015-2020	4	2001	20%	2016 (increasing further thereafter)
DE	Since 2002	0	2002	20%	longer term
FR	2013-2017	2	2008	Ca. 8%	2017
LU	2009-2013	0	2009	Ca. 5%	-
BE (WAL)	2013-2020	0	2013	14%	2020
NL	-	2	2001	-	-

In Switzerland, there is no Action Plan for organic farming. However, the Ordinance on Direct Payments contains various incentives for the promotion of organic farming, such as the so-called "biodiversity subsidies", which promote species and habitat diversity, or production subsidies, which, amongst other things, include subsidies for organic production or extensive production.

4.2 ICPR Programme for the Sustainable Development of the Rhine (Rhine 2020)

The ICPR programme "Rhine 2020", which was adopted in the 13th Conference of Rhine Ministers in Strasbourg in 2001,²⁰ envisages, amongst other things, the application of the EEC Directive concerning the placing of plant protection products on the market (91/414/EEC) by the ICPR member states, with the aim of improving water quality and the further reduction of diffuse substance influxes into water, in particular of plant protection products, by promoting environmentally sustainable agricultural practices.

The following measures are envisaged:

- The promotion of environmentally sustainable land management, organic farming, extensification and the adoption of functions that are beneficial to land cultivation throughout the agricultural sector.
- The further reduction of diffuse substance influxes into water bodies, especially of plant protection products, by promoting environmentally sustainable agricultural practices — in Switzerland, for example, by promoting integrated agricultural production, and promoting organic farming and extensification.

Measures encouraging organic farming were present in the states in the Rhine catchment area before the Rhine 2020 Programme (see ICPR report 109). The current situation regarding organic farming and the National Action Plans are presented in Section 4.1.

¹⁹ 5. Action Programme for Organic Farming 2015-2020, The Austrian Federal Ministry of Agriculture, Forestry, Environment and Water Management, 2015

²⁰ [Rhine 2020](#)

4.3 National level

The European guidelines referred to in Section 4.1 do not outline specific measures for the reduction of plant protection product influxes into the aquatic environment. Measures are, however, described, for example, in the EU member states' Action Plans under 4.1. The measures can therefore differ at a national level, and cover different areas. These can be measures at source, such as approvals, usage bans, targeted subsidies, and information as well as technical reduction measures. Table 3 provides an overview of the situation and includes (amongst other things) measures described in the National Action Plans.

Policy targets

Switzerland

- An Action Plan is currently being drawn up to reduce the risks to humans and the environment associated with the usage of plant protection products. The draft stipulates that by 2026 the usage of plant protection products with a high risk potential for humans and the environment will be reduced by 30%, their emissions by 25%, and the number of areas where the numerical thresholds for water quality are exceeded will be halved.

Austria

- Implementation of the strategy "Future Crop Production" - 10 point programme with the following key points (inter alia): reduction of the use of plant protection products, clear and transparent framework conditions for the approval of plant protection products, the correlation of practice and research, educational campaigns for modern crop production
- Inter-State, National Action Plan for the Sustainable Use of Plant Protection Products

Germany²¹

- According to the WFD, at the latest by 2027, EQS for priority plant protection products and relevant metabolites in surface waters must not be exceeded; levels of 0.1 µg/l (single substance) or 0.5 µg/l (total) in groundwater and surface waters for drinking water production must not be exceeded.
- The creation of shoreline margins with perennial vegetation of at least 5m in width: by 2018 alongside 80% of surface waters in sensitive areas, by 2023 100%; reduction of the risk potential of the applied plant protection products for water organisms: 20% by 2018, and 30% by 2023.
- Use of plant protection product apparatus which is equipped with fresh water for cleaning in the field: 80% by 2018, 100% by 2023.

Luxembourg

- By 2021, the substitution of the most dangerous plant protection products with less hazardous substances, or the implementation of alternative techniques. Consideration of restrictions on non-commercial use and possible prohibitions of these products.

Determining of substances of concern on the basis of toxicological and quantitative criteria and aiming for a 30% reduction of these substances.

²¹ See also the publication National Action Plan for the Sustainable Use of Plant Protection Products (NAP), BAnz AT 15.05.2013 B1

The Netherlands

- According to the WFD, at the latest by 2027, EQS for priority plant protection products in surface waters must not be exceeded; levels of 0.1 µg/l in surface waters for drinking water production must not be exceeded. In surface waters: By 2023, 90% fewer instances of levels being exceeded and 95% for drinking water production with regard to other plant protection products.^{22,23}
For groundwater, the current policy is geared towards tackling the problem of groundwater quality. An investigation is also currently under way to determine whether a supplementary policy aimed at further improving groundwater quality is possible.
- Within the framework of the "delta approach" with regard to water quality and fresh water, which supplements the management plans and, in particular, relates to substances such as plant protection products, supplementary measures will be examined.

²² Nationaal Actieplan duurzame gewasbescherming, Ministerie van Infrastructuur en Milieu, The Hague, 2012

²³ Gezonde groei, duurzame oogst - tweede nota gewasbescherming, periode 2013-2023, Ministerie van Economische Zaken, The Hague, mei 2013

Table 3: Table summarising the measures in the countries of the Rhine catchment area.

		CH	AT	DE	FR	LU	NL
1. Legal measures							
Approval	As per (EC) 1107/2009 approved until	PPP / biocide	PPP / biocide	PPP / biocide	PPP / biocide	PPP / biocide	PPP / biocide
Bentazone	30/06/2017	+/-	+/-	+/-	+/-	+/-	+/-
Carbendazim	30/11/2014, but thiophanate methyl until 31/10/2017	+/+	-/+	-/+	-/+	-/-	-/- (but metabolite of thiophanate methyl)
Chlorotolurone	31/10/2017	+/-	+/-	+/-	+/-	-	-/-
Desethylatrazine		Source product not approved	Source product not approved	Source product not approved	Source product not approved	Source product not approved	-/-
Diurone	30/09/2018	+/+	-/+	-/+	-/+	-/+	-/+
Glyphosate	30/06/2016	+/-	+/-	+/-	+/-	+/	+/
Isoproturon	30/06/2016	+/+	-/+	+/+	+/-	+/	+/
Mecoprop-p / Mecoprop	31/01/2017	+/- ²⁴	+/- ²⁴	+/- ²⁴	+/-	+/-	+/
Ban on usage							
Sealed areas		Yes, for herbicides	Some plant protection products' hazard and safety instructions state that no application is permitted if there is a major risk of flooding. In Vorarlberg (= Rhine catchment area) there is a decree that serves as a ban for the land under the jurisdiction here.	Yes, for herbicides (exceptions possible)	Currently no ban, but financial incentive from local authorities for a transition to "zero pesticides". Ban on road network planned from 01.01.2017	Yes, on public surfaces from January 2016 (herbicides)	Yes, ban on sealed surfaces from 31st March 2016 for commercial users and a potential permanent ban for private users. Exceptions are set out in the legislation.
Other surfaces (also drained areas or areas at risk of leaching)		On and along streets, paths and squares (+50 cm margins) as well as on roofs (herbicides — however only as plant protection products, not as a biocide contained within the material)	Ban in wetlands, meadows and grasslands or dry sites as well as in the three meter-wide land margins adjoining these, in the three meter-wide land margins adjoining the forest or the upper edge of the shore of surface waters, in other areas, in particular in residential or agricultural areas, if a detrimental effect on the health of people living close by, or the plants in the area or plants growing on adjacent land is to be anticipated.	Some requirements in terms of soil conditions, vegetation, slope gradients or time of application	For local authorities to maintain green areas, forests or publicly accessible or open paths from 01.01.2017. For non-professional applications, from 01.01.2019. For farmers, for certain plant protection products on dehydrated surfaces (permanent ban or ban during the period of seepage discharge)	On public areas from January 2016 (herbicides)	Ban outside of agricultural applications, from September 2017 for commercial users. For sports grounds, supplementary agreements were concluded (so-called 'green deals').
Requirements regarding drinking water protection areas		Protection Zone S1 (as a rule, 10 m around springs): Total ban Protection Zone S2 (in loose rock: at least 100 m in inflow direction and from the outer edge at least 10 days' delay before collection): some selected active ingredients are prohibited (e.g. bentazone, isoproturon)	Yes, specifically depending on the protected area or protection zone, there are different restrictions (prohibitions, restrictions of use, notification obligations, etc.)	Basic usage ban for non-agricultural land § 12 para. 2 Plant Protection Act [PflSchG]; Order on the use of plant protection products (§ 1 – 3)	Yes. In addition to regulations, financial support for voluntary ground-based measures that enable sustainable protection of resources	Yes	Yes, via WFD in territorial documents
Financial instruments							
Levies:							

²⁴ Although mecoprop is not approved as a biocide, substances are incorporated into bituminous roofing membranes which, when they come into contact with water, produce mecoprop, which then acts as protection against root penetration.

	CH	AT	DE	FR	LU	NL
Levy/fee on plant protection products		No	No	Levy present since 2008. The revenue from this levy will subsequently be used to finance support measures		No
Subsidy for:						
Organic products	Yes	Yes, European Agricultural Fund for Rural Development (EAFRD)	Partial	Yes		Yes but voluntary, and there is no objective associated with it
Environmentally conscious operation management	Yes	Yes, European Agricultural Fund for Rural Development (EAFRD)	Partial; support for farming, not of products	Yes		Yes
Extensive agriculture	Partial	Yes, European Agricultural Fund for Rural Development (EAFRD)	Partial, European Agricultural Fund for Rural Development measures (EAFRD)	Yes	Partial, via measures included in plan for rural development	No
In terms of environment, fewer hazardous products	Partial subsidy for insecticides with the fewest possible side effects on terrestrial non-target organisms	Yes, European Agricultural Fund for Rural Development (EAFRD)	Partial, European Agricultural Fund for Rural Development measures (EAFRD)	Yes	Yes	Guidance toward low-risk resources (without objective setting)
Environmentally conscious behaviour	Partial	Yes, European Agricultural Fund for Rural Development (EAFRD) and consulting services in the federal states	Yes (consulting concepts)	Yes		Yes, project approach of sector
Funds for Rural Development	Establishment of Action Plan in progress	Yes	Yes	Yes	Yes	Yes, via National Action Plan and complementary policy (Memorandum Healthy Growth, Sustainable Harvest)
2. Technical measures						
Wastewater treatment plants	Reduction of discharge (4th treatment stage) resolved for around 50% of the municipal sewage	Federal competencies, no area-wide expansion to include 4th treatment stage in Vorarlberg wastewater treatment plants; monitoring of surface water bodies and groundwater with regard to plant protection products	In some federal states, funding for expansion of sewage treatment plants to include 4th treatment stage	For certain pesticides, ban on exceeding certain maximum loads	Information for providers, in the case of development: Plan specification of space for potential 4th treatment stage	In the longer term potentially 4th treatment stage (possibly special plant protection product stage for greenhouse cultivators) i.e. regionally feasible and affordable
Shoreline margins	3 m (in general), 6 m (efficiency statement in agriculture); watercourse also wider in part (up to 15 m sections of shore for still waters and wide rivers). Product-specific distance requirements of 6m within the framework of approval	Product-specific requirements (e.g. minimum distances to bodies of water) and shoreline margins or land set aside within the framework of the European Agricultural Fund for Rural Development (EAFRD)	Up to 10 m, country specific regulations; (e.g. use of drift-reducing nozzle technology)	Product and application-dependent non-treated minimum range of 5 m to 100 m around water points	3 m (water bodies wider than 2 m) 100 m for reservoir	0.25 - 9 m (current planning: from 01.01.2017 at least 0.5 m), depending on crop (largest areas especially for fruit farming). Larger areas in open crops for intensely sprayed plants.
Reduction of drift	Yes (product-specific requirements: 6-100 m distance; can be reduced to 6 m through drift-reduction measures)	Product-specific requirements (e.g. no application if there is a risk of drift onto adjacent surface waters)	Some requirements in terms of soil conditions, vegetation, slope gradients or time of application	Financial support for the establishment of buffer zones (watercourse shoreline margins, forest, hedges, etc.) and for provisions for the prevention of drift	Yes	Increase in drift reduction from 50% to 75%; in the long term an investigation shall be undertaken as to whether 90% drift reduction is required. A reduction of more than 90% is a key component of in-depth investigations regarding feasibility and implementation.
Reduction of surface run-off	Cf. shoreline margins and regional programmes possible (Art. 62a Water Protection Act [GSchG], Art. 77a Federal Water Act [LWG]), but hardly used up to this point. Plant protection products envisaged as priority topic in AP.	Product-specific requirements and shoreline margins or land set aside within the framework of the European Agricultural Fund for Rural Development (EAFRD)	Some requirements in terms of soil conditions, vegetation, slope gradients or time of application	Financial support for the establishment of buffer zones (shoreline margins)	Yes	Projects. In terms of approval, the assessment of surface run-off is missing.

	CH	AT	DE	FR	LU	NL
Reduction of erosion	Cf. shoreline margins and contributions for careful soil cultivation; regional programme (Art. 77a LWG); CH map of erosion)	Yes, European Agricultural Fund for Rural Development (EAFRD)	Some requirements in terms of soil conditions, vegetation, slope gradients or time of application	Financial support for the establishment of buffer zones (shoreline margins) + recommendations for the management of slopes		No
Reduction of leaching	No	Yes, European Agricultural Fund for Rural Development (EAFRD), e.g. areas set aside	Some requirements in terms of soil conditions, vegetation, slope gradients or time of application	Financial support for the establishment of buffer zones (shoreline margins)	No	Yes, limited
Reduction of influxes due to drainage	No	No	Some requirements in terms of soil conditions, vegetation, slope gradients or time of application	Financial support for the establishment of buffer zones (man-made wetlands)	No	Some pilot projects in the past that were not further pursued. Assessment of means of approval is missing.
Ban on spraying from the air	No (special authorisation required)	Yes	Yes	Yes (exceptional approval possible in case of emergency regarding health)	Yes (permitted in viticulture with approval)	Yes (exceptions in emergency situations possible, upon exemption by authorised authority). To date, no exception has yet been granted.
Treatment of discharge from greenhouses.	Situation unknown. Legal situation: Discharge containing plant protection products must be treated separately.	No			No	>95 % (2018)
Precipitation	Requirements for some plant protection products: at least 6 hours with no precipitation forecast after application	In terms of warning services, attention is drawn to the fact that precipitation events must be taken into account	Some requirements at time of application	General recommendation to refrain from treatment if there is a risk of precipitation within 2 to 3 hours of spraying	No	24-hour spray ban on sealed surfaces in the case of > 1 mm rain. From 2016, complete ban
Wind	Instruction of approval body: no application in the case of wind > 5.4 m/s	Via further education courses; consultation on drift-reduction equipment	Use of drift-reduction nozzle technology	Spraying or dusting only at wind speeds ≤ 3 Bf (<5.3 m/s)	No	Spraying at < 5 m/s
3. Increasing awareness and information for the commercial sphere and public						
Information for the general public	To a limited extent: information campaigns to raise awareness among private users in order to encourage respect for usage ban.	Yes	Some recommendations	Yes	Yes	Yes
Certificate of competence for non-private users	Yes, but limited validity. No proof of further training necessary.	Yes	Yes, as per § 9 para. 1 PflSchG	Obligatory for professional use. Voluntary for private individuals	No	Yes, inter alia, licenses for spraying on the basis of informational events. For professional users, a certificate of competence is obligatory.
Training for farmers	Yes, but as above.	Yes	Yes	Yes	Yes	Yes
Advising farmers	Yes (but publicly sharply declining, often by companies)	Yes	Yes	Yes	Yes	Yes
Raising awareness	In a few special projects under Art. 62a GSchG or Art. 77a LWG	Yes	Yes (advice); some special projects	Yes	Yes	Yes, via projects in the sector
4. Monitoring programmes						
Discharge of wastewater treatment plants	Individual campaigns, but not systematic	Not systematic	Not systematic	Regularly for wastewater treatment plants with more than 10,000 population equivalents	Not systematic	Yes
Surface water bodies	Individual campaigns, but not systematic	Yes	Yes	Yes	Yes	Yes, WFD, regional waters and specific monitoring network for plant protection products in agriculture.
Groundwater	Yes, national monitoring network of the Federal Republic and the Cantons with ca. 550 monitoring points	Yes	Yes	Yes	Yes	Yes

Key:

- CH** Switzerland
- AT** Austria
- DE** Germany
- FR** France
- LU** Luxembourg
- NL** The Netherlands
- +** Approved
- Not approved

The overview of the national measures in the countries in the Rhine catchment area (Table 3) shows that measures are already being taken in all countries under consideration here to reduce plant protection product influxes, but these differ greatly in some cases.

Some of the active ingredients of plant protection products that are currently comprehensively approved are bentazone, glyphosate and mecoprop/mecoprop-p, although the applications of these can differ greatly. The other plant protection product active ingredients considered here are in some cases not approved or, as for example in the case of diuron, have been approved primarily as a biocide. Atrazine is not authorised in any country in the Rhine catchment area, and the two active ingredients carbendazim and diuron are only authorised for use as plant protection products in Switzerland. Approval for the active ingredient isoproturon was not renewed at the end of June 2016; the period of use ends no later than 30th September 2017²⁵.

The approval for glyphosate, which expired at the end of June 2016, was extended by 18 months instead of another 15 years. During this time the carcinogenicity is to be re-evaluated.

Usage bans are issued in the member states particularly in drinking water protection areas and on sealed surfaces. From 2017, there is a ban on the application of herbicides on sealed surfaces in all member states.

In order to reduce the use of harmful active substances in plant protection products, certain farming systems, e.g. organic farming are financially supported. These subsidies often only come into effect partially however, or are not linked to precise water protection objectives. Another financial instrument can be levies. Thus far, a levy on plant protection products is collected only in France, to finance other measures to reduce plant protection products. The aim of the levy is to achieve a steering effect and to increase the competitiveness of companies with lower plant protection product use.

There are still major differences or different approaches between the member states in terms of technical measures. Measures regarding individual influx pathways are more or less present in all member states. For example, shoreline margins are prescribed in all member states, however the extent of these varies. Airborne spraying is either prohibited, or a special permit is required, in all member states. For other influx pathways, there are no uniform procedures. For example, specific requirements are imposed, financial incentives are created, or attempts are made via various projects to minimise individual influx paths. In Chapter 3, surface run-off, leaching and drainage were identified as the most important influx paths for the substances under consideration. Table 3 shows that specific measures for the reduction of these influx pathways are either missing entirely in most of the countries (drainage) or vary greatly (shoreline margins for the reduction of surface run-off). Influxes via municipal wastewater treatment plants, which are accounted for under "other influxes", can be reduced to a certain extent where further treatment stages are present, but this technique does not represent the first choice measures for reducing plant protection products.

In terms of commercial information, training is provided in all member states, as well as guidance for farmers. In some locations, there are also targeted awareness campaigns for farmers. The general public is also provided with information, albeit only to a limited extent in some locations. In addition, for non-private users, in some locations certificates of competency are required. Despite the many measures in place for providing information to both the commercial sphere and the public, deficiencies are apparent. For example, certificates of competency and training are often valid for an unlimited period; training is sometimes not compulsory or does not include a certificate of proficiency on the basis of regular examinations. Furthermore, farmers are increasingly advised by commercial enterprises.

²⁵ Implementing Regulation (EU) 2016/872

Monitoring programmes are systematically implemented in the EU countries, for surface water and groundwater, as they are also required under the WFD. Further measurements, e.g. of wastewater treatment plant effluents, or specific measurements relating to plant protection products are not yet systematically under way in all member states.

4.4 Pilot projects

In addition to the National Action Plans referred to under 4.1 and 4.3, pilot projects are being implemented in the relevant member states and at an international level, in order to bring about a general reduction in the use of plant protection products, or their influx into bodies of water.

An example of an international project that deals with the reduction of the influx of plant protection product into water bodies is TOPPS (<http://www.topps-life.org/>), a project financed by the European Crop Protection Association (ECPA). Here, problems relating to certain influx pathways are outlined, and practical recommendations are given. Projects aimed at reducing plant protection products in water bodies are also being implemented on an international level, to a lesser degree. In the Moselle area, an INTERREG V A project is being prepared, which is to be implemented by Luxembourg, Wallonia, the Saarland, Rhineland-Palatinate and Lorraine under the direction of the Lorraine Chamber of Agriculture. In addition to the exchange of expert knowledge, measures for the reduction of plant protection product use and influxes into water are to be devised.

Information campaigns and projects are also being implemented on a national level, in order to reduce the amount of plant protection products in bodies of water. Further information can be found in Appendix 2.

5. Conclusion

The analysis shows that drainage, leaching and surface run-off are the most relevant, diffuse influx pathways for the plant protection products selected here.

At the Ministerial Conference of the Rhine in 2013²⁶, ministers and representatives of the European Union made a commitment to an initiative regarding the development of activities to establish a consistent chain of measures from source to disposal for products containing water body-relevant substances.

The ICPR will develop recommendations for action on the basis of the present conclusions. These recommendations should be regularly reviewed.

5.1 Potential measures for reducing diffuse influxes of plant protection products

Various measures can be implemented on different levels in order to minimise (reduce) the influx of plant protection products:

- measures at source;
- technical measures;
- adaptation of monitoring and evaluation systems;
- information for the public.

The potential measures are outlined in greater detail below.

²⁶ [15. Ministerial Conference of the Rhine - Minister Communiqué](#)

- a. Measures at source (approval, restriction of the use of substances, production processes, regulations regarding disposal);

In view of the diffuse influx pathways, measures aimed at reducing the use of these substances, or measures for the reduction of the risk of influx into surface waters are the most promising. The continuous reduction of usage is an effective measure for the protection of bodies of water, and appropriate agricultural policy incentives must be developed. Other approaches are aimed at risk reduction. For example, plant protection products with a lower risk potential could be preferentially selected, or subsidised. Approvals and regulations should therefore lead to a general reduction of risks and/or a reduction in usage.

The influx paths drainage and surface run-off should be given more attention in terms of approvals. In terms of approval modelling, these influx paths are often not, or insufficiently, considered. It is recommended that approval is only given to usages that do not lead to the concentrations specified in Regulation (EC) 1107/2009 (Regulatory Acceptable Concentrations = RAC) being exceeded in terms of drainage and surface run-off. Steering measures, such as a special tax on plant protection products, have thus far not been tested. These could supplement the range of measures implemented in the member states. Currently, this financial instrument has only been applied in France.

In the **agricultural sector**, a reduction in plant protection products influxes into water bodies, and the concomitant risks, can be achieved through the use of modern, precise application methods, the cultivation of adapted crops, and the promotion of integrated production or even organic farming. A specific measure is, for example, the mechanical removal of weeds, instead of the use of plant protection products. In addition, good agricultural practices must be implemented on a large scale and, for example, when cleaning spraying devices, care must be taken that the wastewater is conducted into the sewage system or, for example, treated separately with biofilters. Good agricultural practice also consists of dispensing with the prophylactic use of plant protection products and, with the aid of extensive knowledge regarding pest infestation pressure, to proceed in a targeted manner in order to also reduce the amount of plant protection products used.

In the **non-agricultural sector**, the usage bans on sealed public areas, which are already in force in the countries in the Rhine catchment area, are an important step. It is anticipated that from 2017 onwards, plant protection products may no longer be used on sealed public areas in the countries in the Rhine catchment area. Other potential measures include the regulation of the sale of plant protection products to private users, for example only allowing sales by trained staff, or only offering "ready-to-use" products rather than concentrates.

The measures at source can be implemented at different levels. Political bodies (such as the EU and NGOs), the agricultural sector and users in the non-agricultural sector can contribute to the reduction of plant protection product influx into water bodies through measures at source. The option of a plant protection product levy could be tested in the member states within the framework of the NAP. This option was explored a few years ago in the Netherlands. It was found that the levy has to be set relatively high in order to produce an effect. In 2013, this measure was deemed undesirable, due (inter alia) to a much higher economic burden on farmers.

- b. Technical measures (measures to reduce individual influx pathways);

It has been established that relevant influx paths for the selected plant protection products are, in particular, drainage, leaching, surface run-off and prevailing flow. The influx is essentially characterised by precipitation. In order to reduce influxes from this influx path, the reforming of the terrain, e.g. setting up larger buffer zones (buffer

margins and green verges) as well as requirements in terms of the soil conditions, vegetation (perennial greenery), slope gradient or application time for the usage of plant protection products (cf. Section 4.3) are expedient.

The bans regarding spreading on sealed surfaces lead to a reduction of the direct influx via rain water discharge. Only through improper handling and accidents during filling and cleaning might there be significant influxes of plant protection products into water bodies here. In terms of rain discharge, plant beds can contribute to a further reduction, and also constitute a key measure for the reduction of the diffuse influxes of other micropollutants from atmospheric deposition or road traffic.

Decentralised measures (treatment of partial wastewater flows) and central measures at municipal sewage treatment plants are taken into consideration for specific influx paths. By setting up special washing and filling sites for agricultural sprayers, the influx due to improper handling can therefore be reduced. A special plant protection product stage (ozonation or treatment with peroxide/UV and potentially additional charcoal) can be useful for wastewater treatment plants with an increased proportion of wastewater from greenhouse farming. Due to the fact that in general, only the plant protection products that are washed away from sealed surfaces can be treated in municipal wastewater treatment plants, the expansion of a plant to entail a fourth treatment stage is not appropriate just for this class of substances, but it can be useful to reduce other micropollutants²⁷.

The implementation of decentralised and central measures is a task for both policy makers, the operators of wastewater treatment plants and the agricultural sector.

- c. Adaptation of monitoring and evaluation systems (addition of monitoring concepts and measurement programmes, taking into account new substances in the assessment of the ecological status of waters, deriving quality criteria);

The extensive range of available plant protection product active ingredients and their constant further development prevent measurement and monitoring programmes from representing a comprehensive overview. In order to be able to monitor the impact of plant protection products on the quality of water, a selection of indicator substances must be used, as in the present report. As such a selection is based on sales volumes and water hazard potential, it cannot be ruled out that different groups of substances or fields of application are insufficiently assessed. A monitoring program would ideally also be based on non-target analysis/screening investigations, which at least at the time of the application of plant protection products represent an important addition to the existing single substance analysis, and also monitor possible degradation products or metabolites of the plant protection products used. The results of such measurement campaigns could be presented as "hit lists" and would provide a more general insight into the load situation as regards water bodies.

In the case of the regular monitoring programs, the situation regarding approvals and authorisation should always be taken into account, and possible substitute substances and new active substances should also be considered. In addition, close cooperation with the agricultural authorities is needed to maintain up-to-date data exchanges regarding consumption levels of active substances and application periods, as the basis for planning monitoring programmes.

Diffuse influx paths are difficult to record by means of water body measurement programmes. In the assessment of these influx pathways and potential measures, it is therefore also necessary to utilise substance flow modelling.

In the member states of the EU, indicators must also be defined for the NAPs (National Action Plans), which can be used to monitor compliance with targets.

²⁷ [ICPR Technical Report No. 203](#)

- d. Information for the public (regarding the relevance of environmental and drinking water, and recommended changes to the application and disposal of substances)

Assessment results regarding the load situation in water bodies due to plant protection products can also be used in information campaigns for the general public. Such awareness campaigns are necessary to provide an understanding of reduction measures at source. Advisory and training programmes for farmers and professional users of plant protection products are under way in the countries in the Rhine catchment area, and are an important part of the National Action Plans.

5.2 Diffuse influxes of other micropollutants

The present report and the method developed therefrom represent a course of action which makes it possible to address the complex issue of the diffuse influx of micropollutants into bodies of water. Due to the heterogeneity of the substance properties as well as the areas of application of the substances, the methodology of the particular issue at hand has to be adapted. The assessment of influx pathways, as shown in this report, as well as the measures presented here apply specifically to plant protection products. Depending on the category of substances, other influx pathways and thus other measures will also come to the fore.

Other diffuse substances such as biocides, heavy metals, PAHs and other organic micropollutants stem not only from agriculture. Bans and restrictions on usage are the most effective means of avoiding entry into bodies of water. However, these measures are not applicable to all substances; moreover, micropollutants often diffuse into waters long after their application. Examples here include very stable compounds such as flame retardants or perfluorinated chemicals. PAHs are introduced into the environment through incineration or abrasion processes, finally filtering into water bodies through rainwater.

In terms of biocides, the possibilities for minimising consumption are to be tested analogously with plant protection products. In addition, increasing awareness and information levels for users and the general public regarding these substances is also of great importance, as is the case with plant protection products. Biocides enter water bodies inter alia via the municipal sewage system, therefore central measures at municipal wastewater treatment plants can be implemented much more effectively than for the elimination of plant protection products. Where biocides stem from use on sealed surfaces or on buildings, these substances are also relevant in the assessment of rainwater-derived influxes.

For heavy metals and PAHs, surface run-off from sealed surfaces, groundwater, erosion and atmospheric deposition are all important influx paths.

For the other above-mentioned diffuse inflowing substances, rainwater via the sewage system is a significant source. In terms of the plant protection products considered here, the relevance of rainwater discharged into the sewage system is therefore lower, as for most member states there is a current or imminent ban on the application of herbicides on sealed surfaces. Measures for the reduction of diffuse influxes of micropollutants must, therefore, in particular also take into account rainwater retention or harmless seepage.

Appendix 1 Substance-Specific Influx Paths per Country in the Rhine Catchment Area

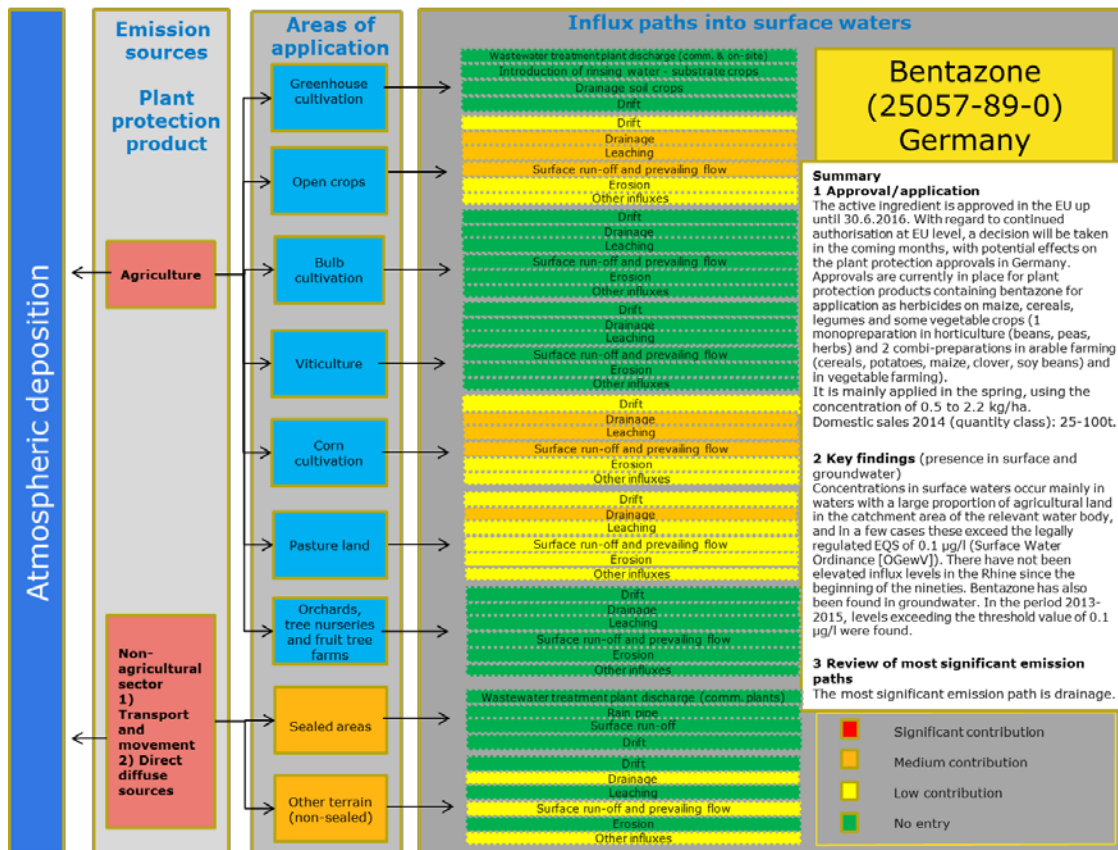
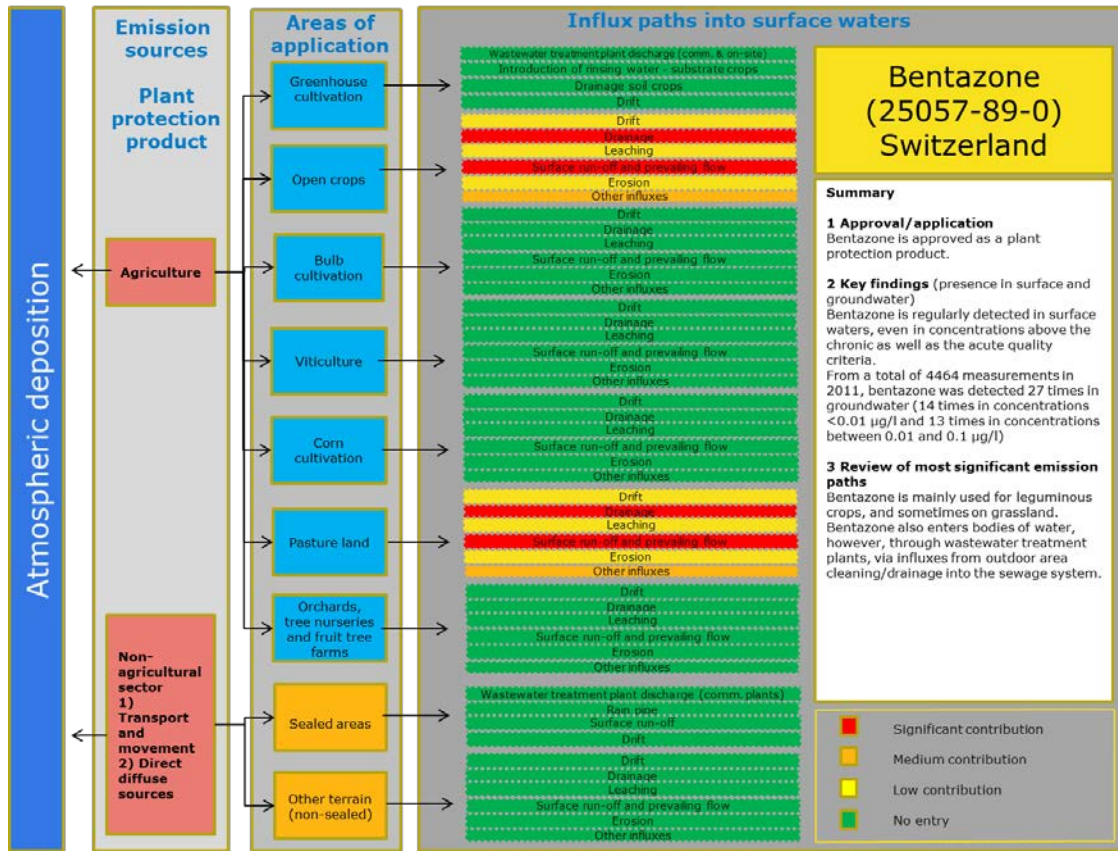

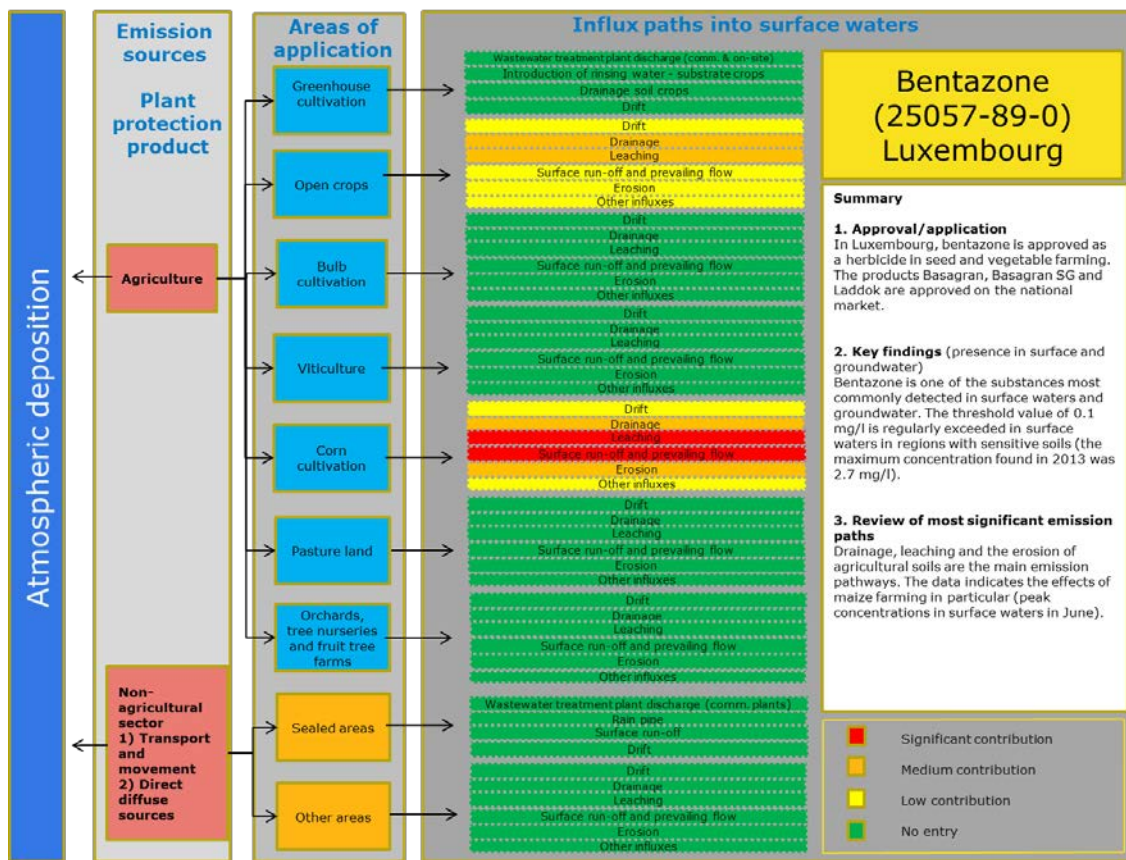
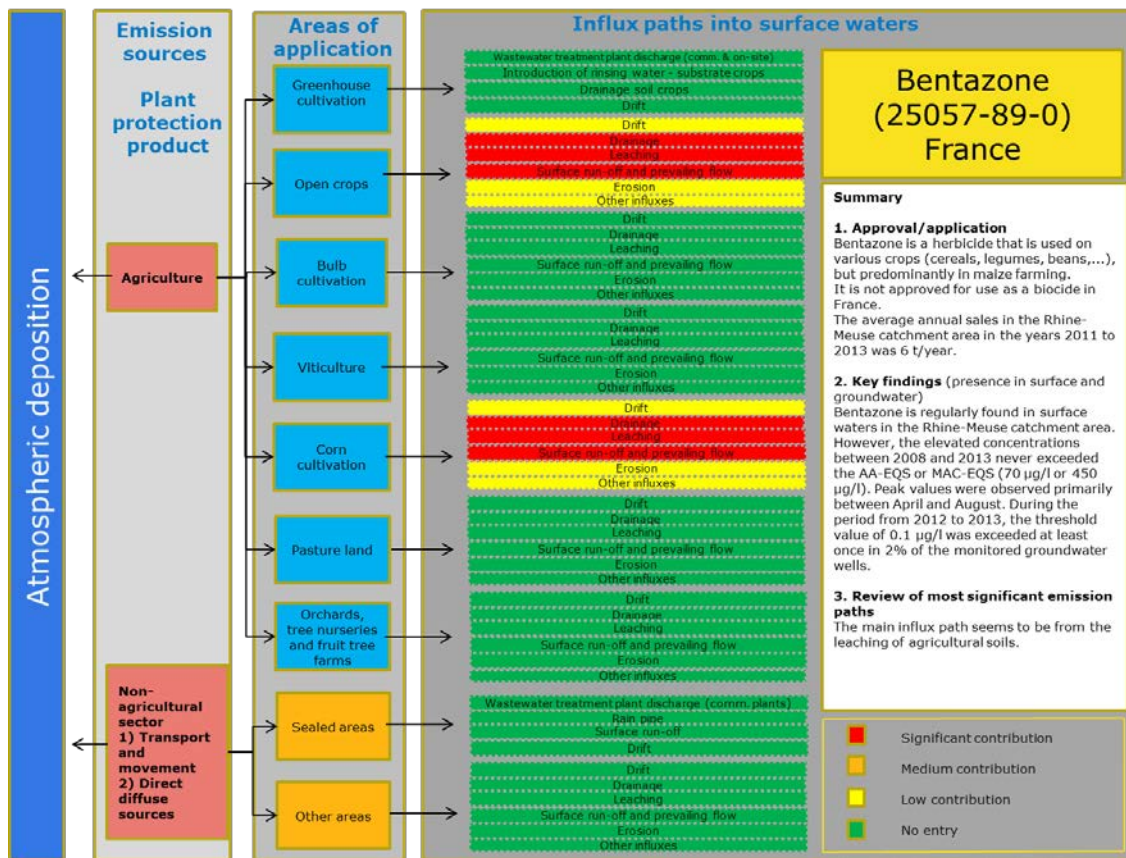

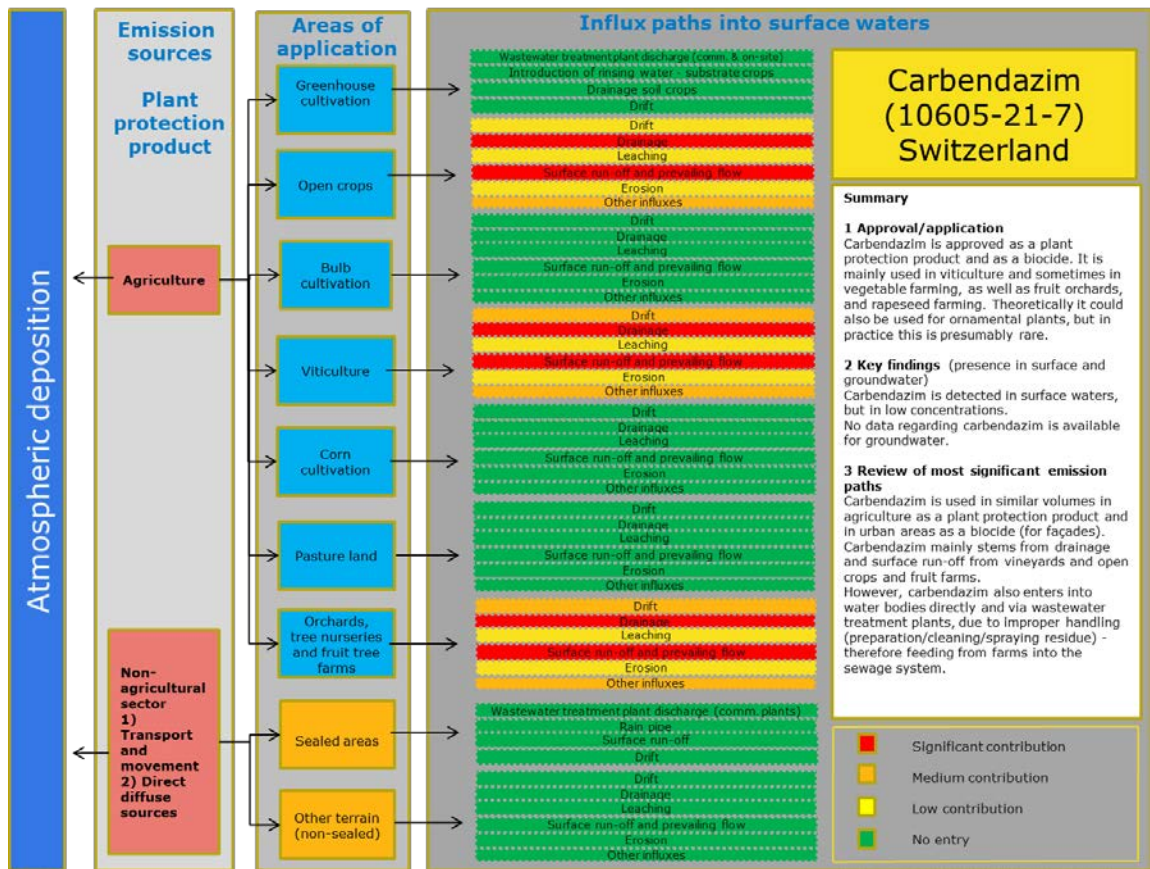
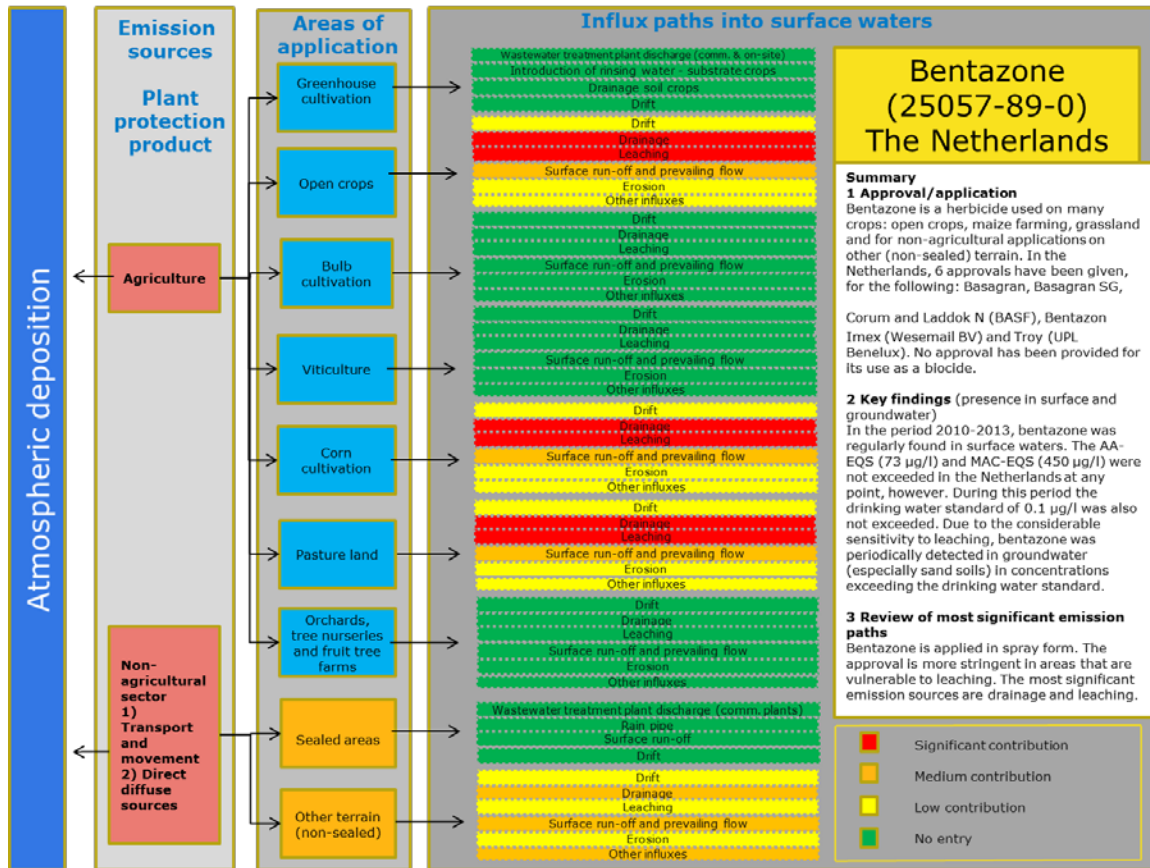

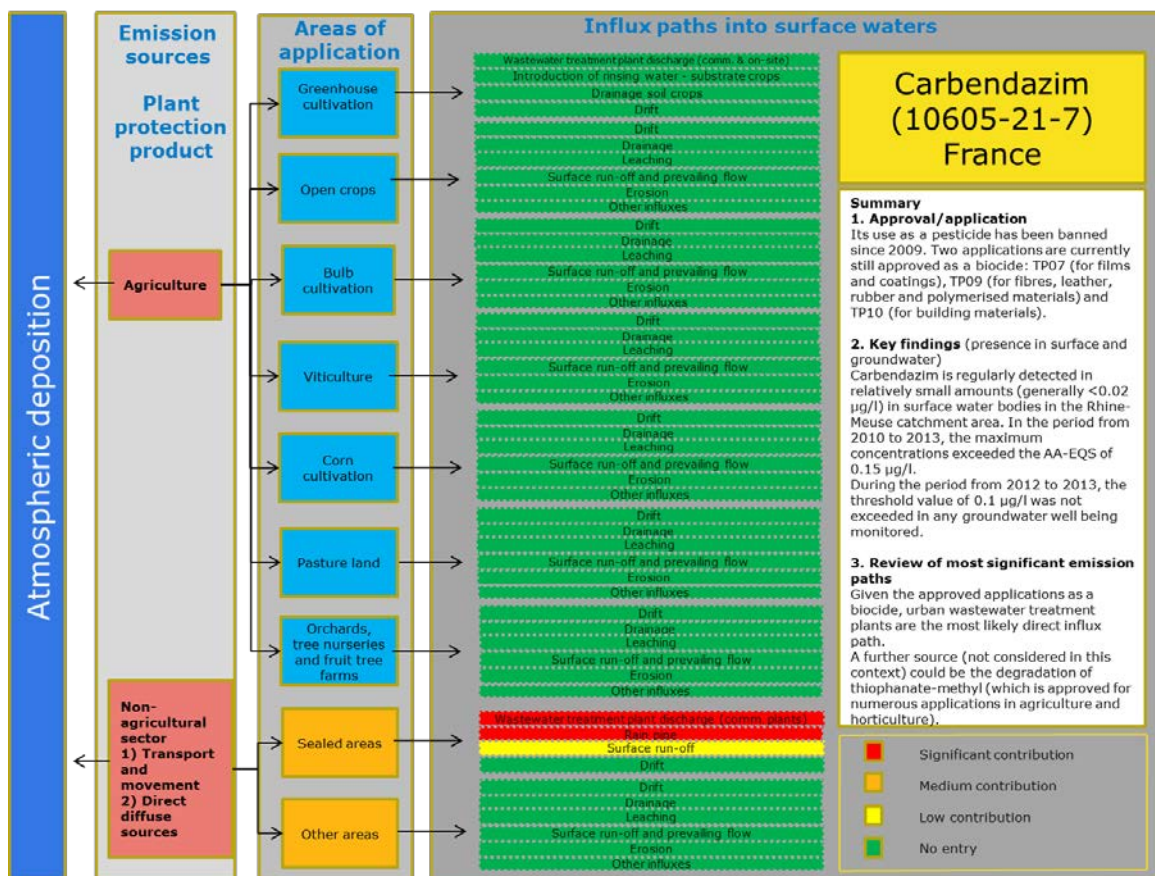
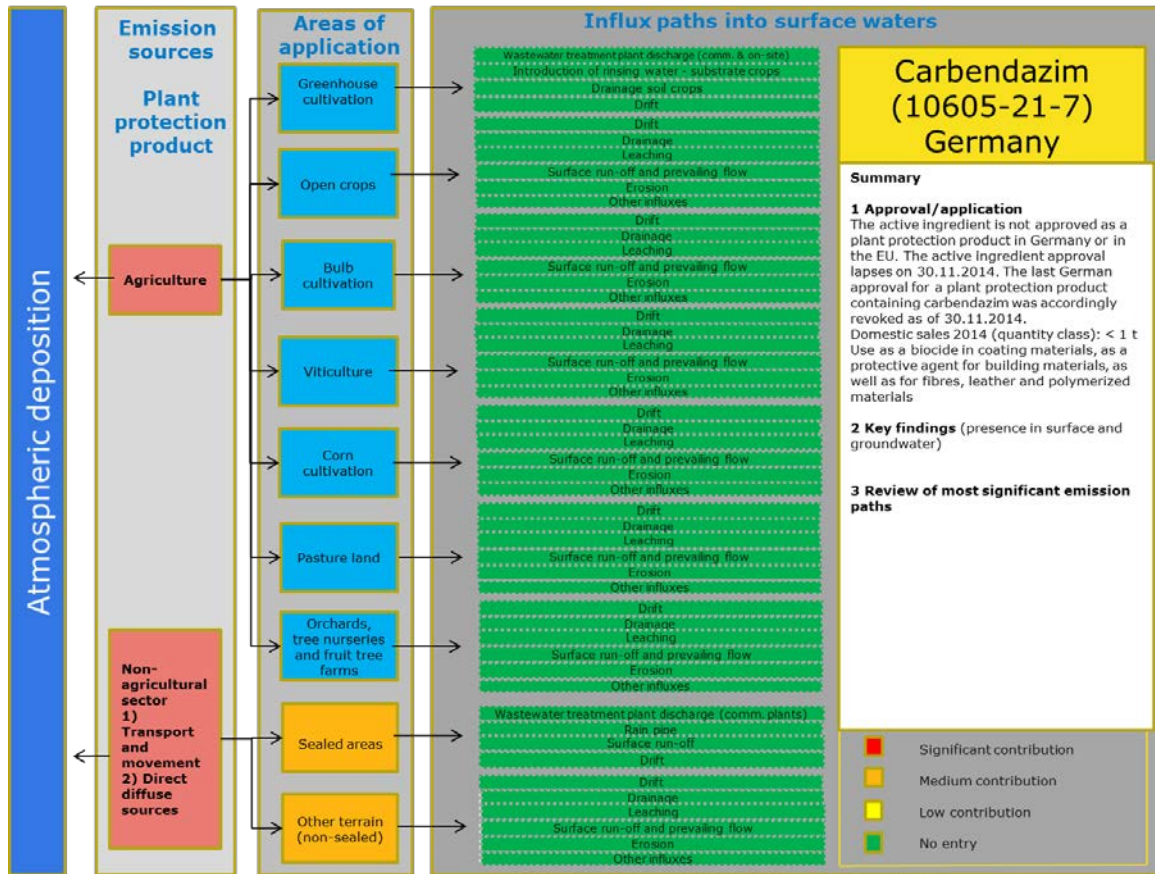

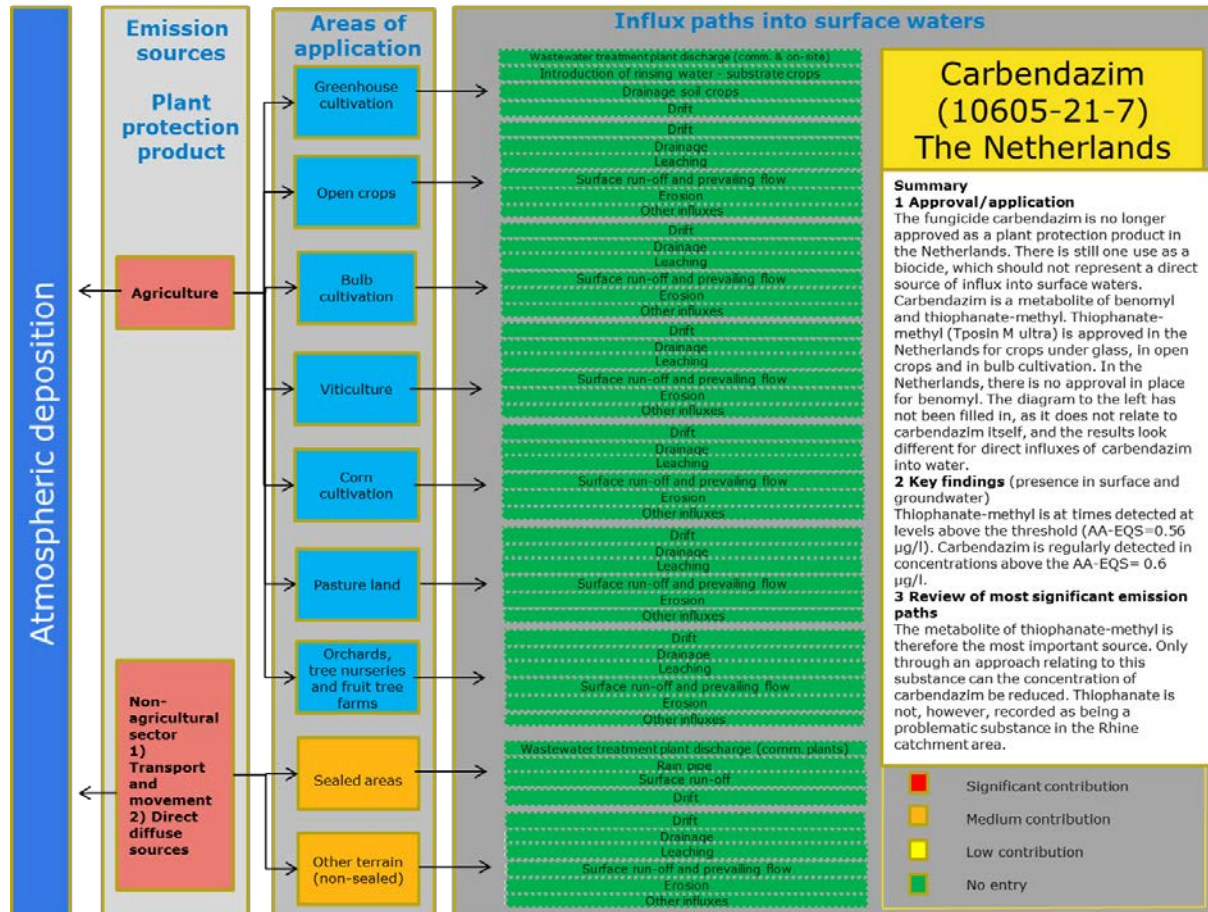
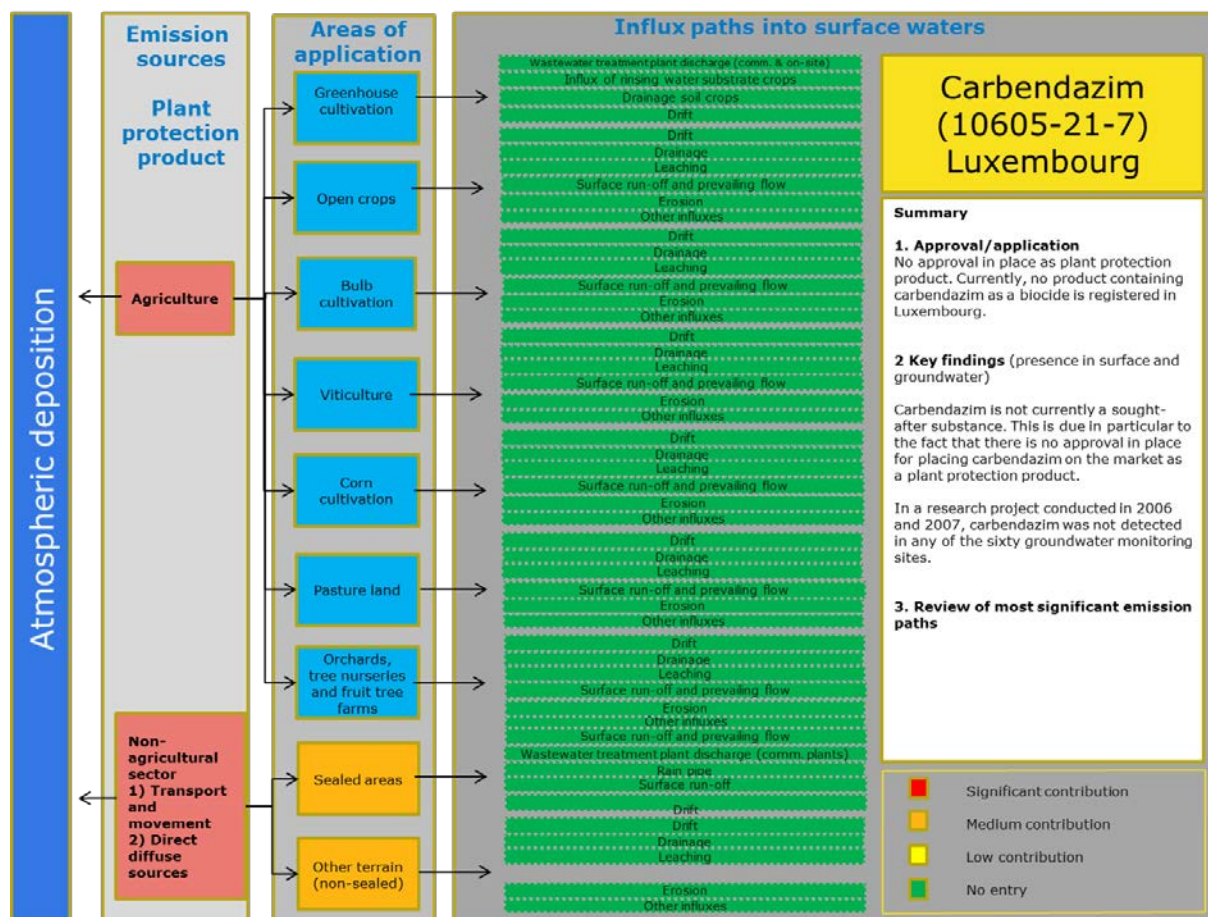

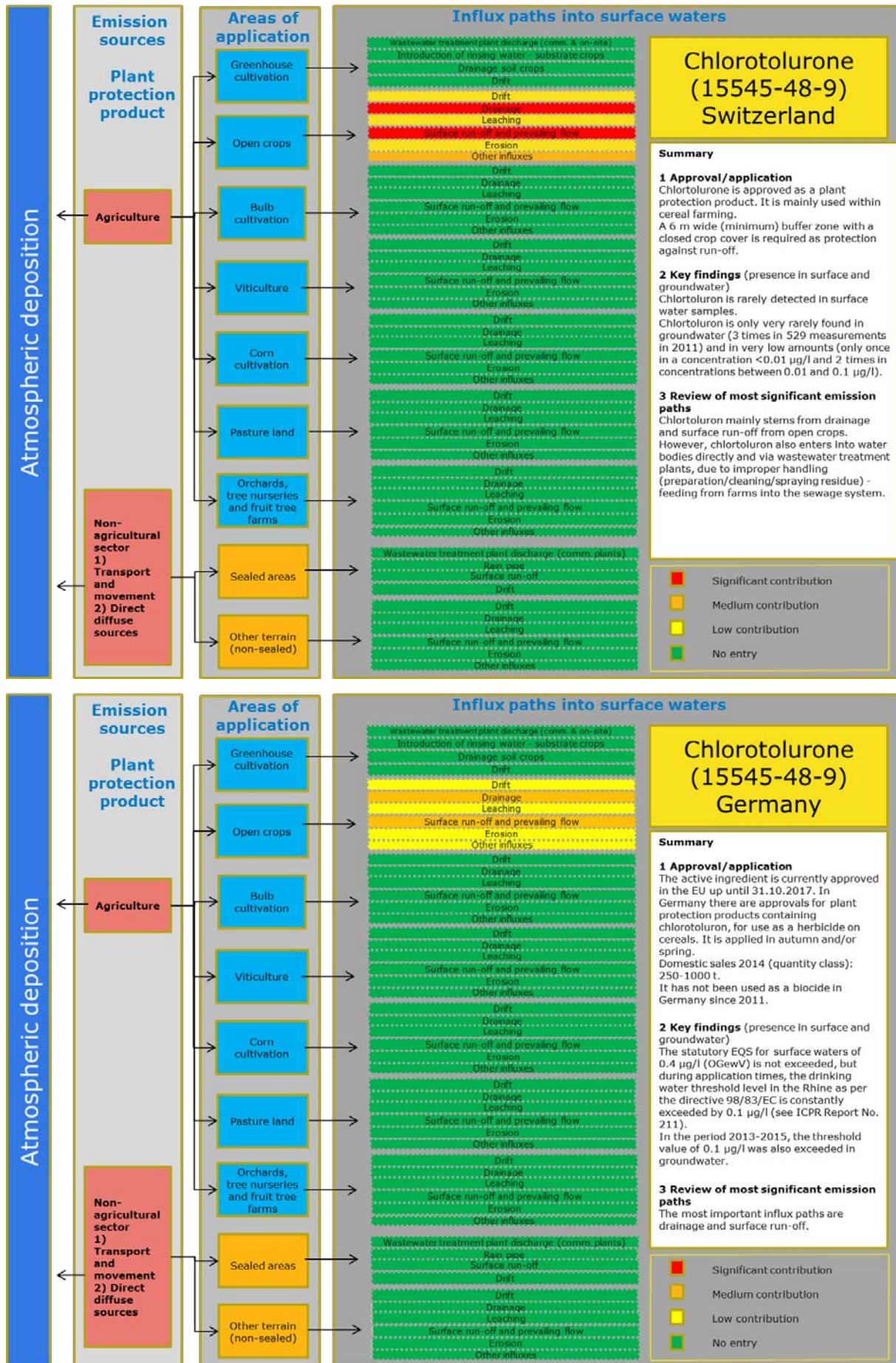

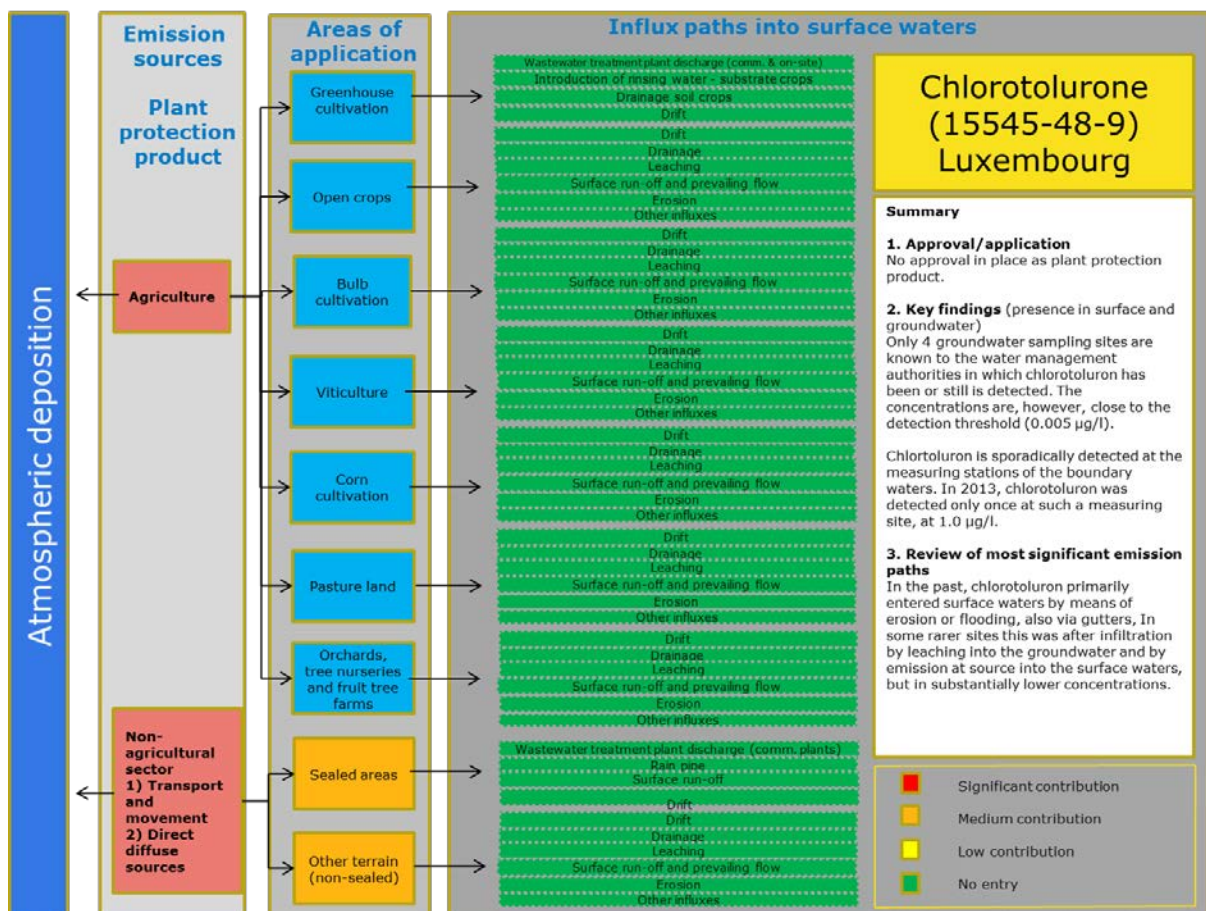
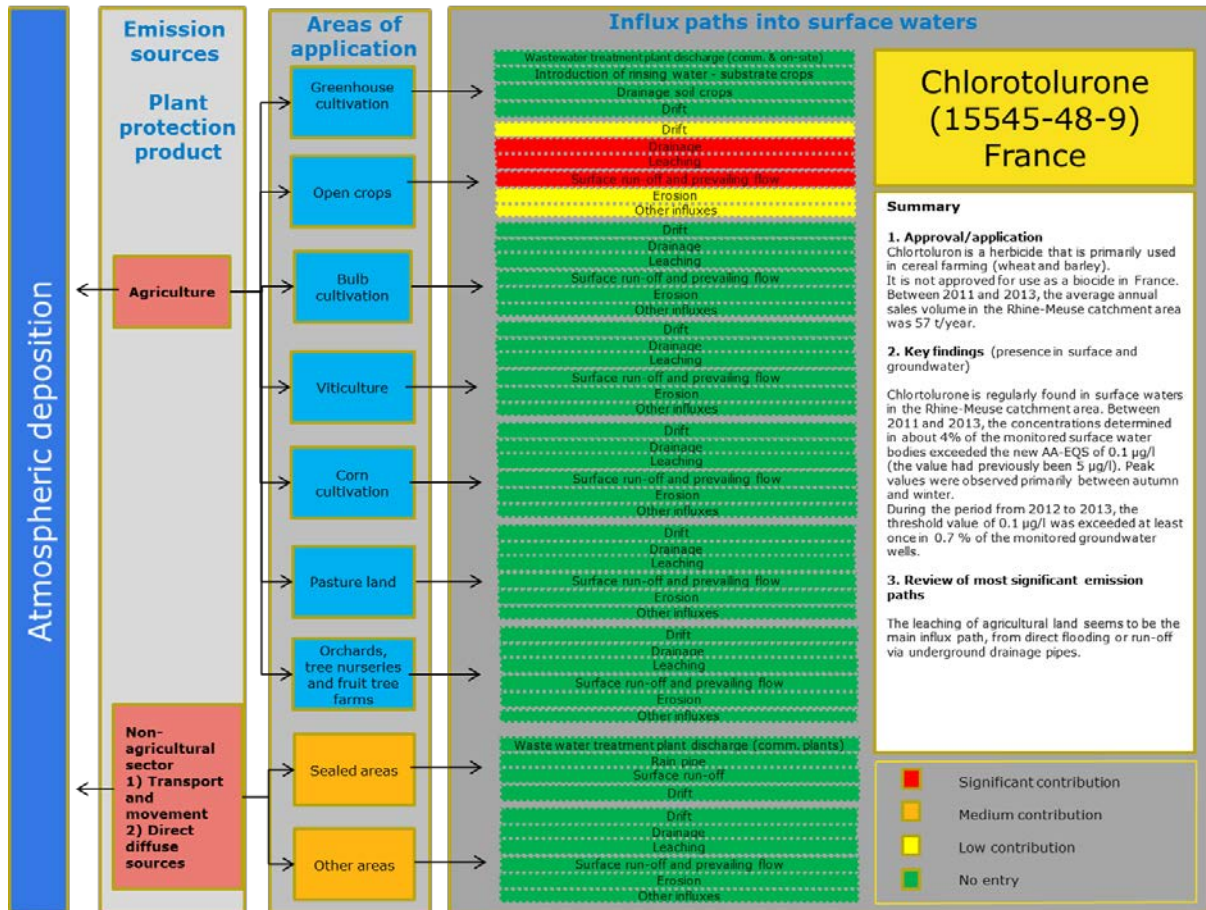

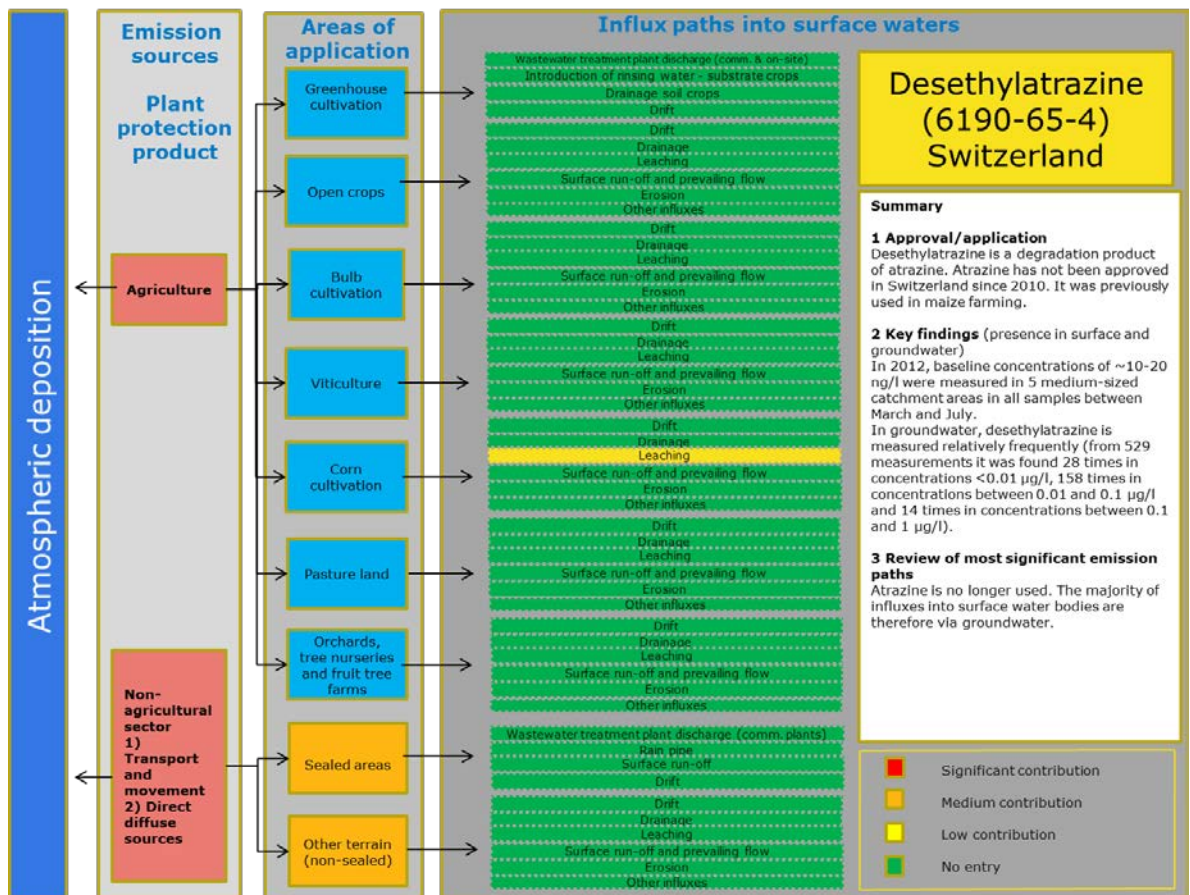
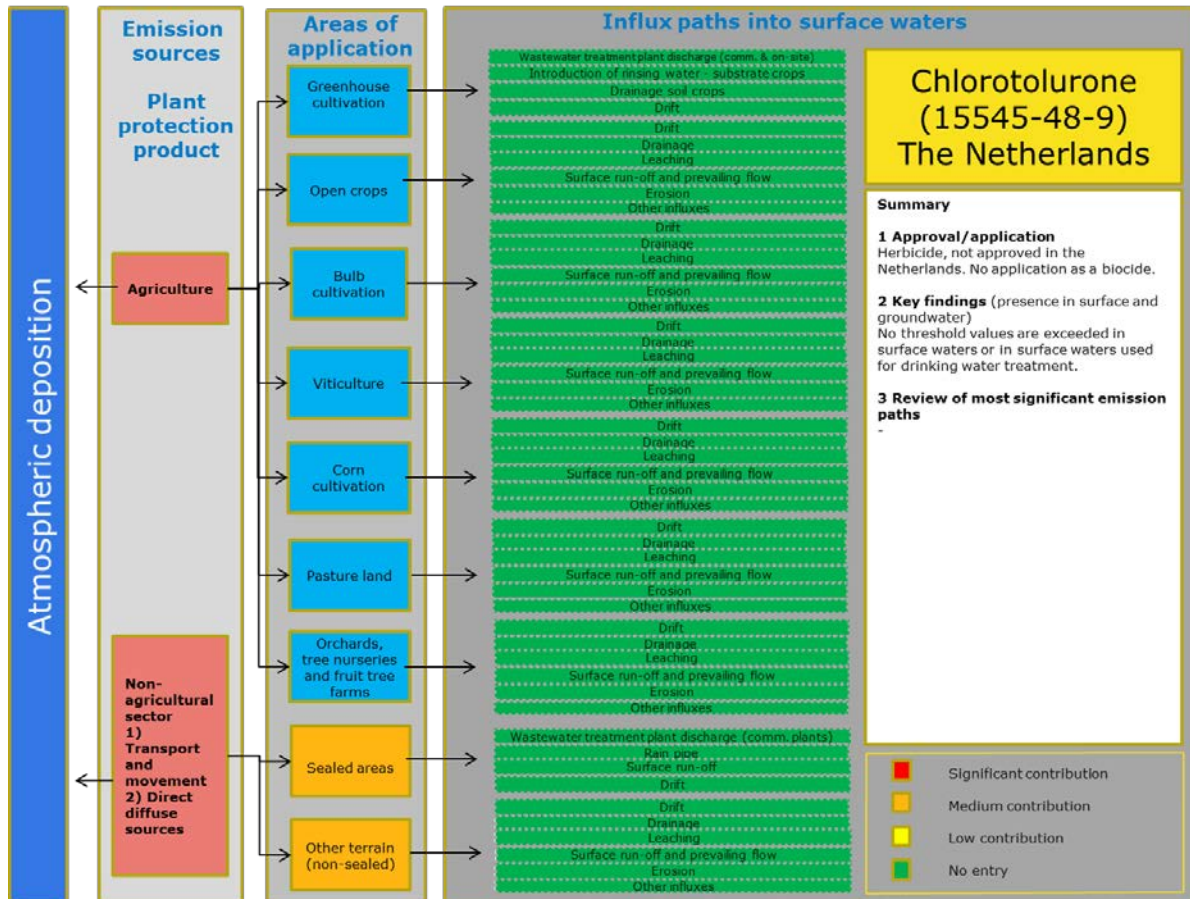

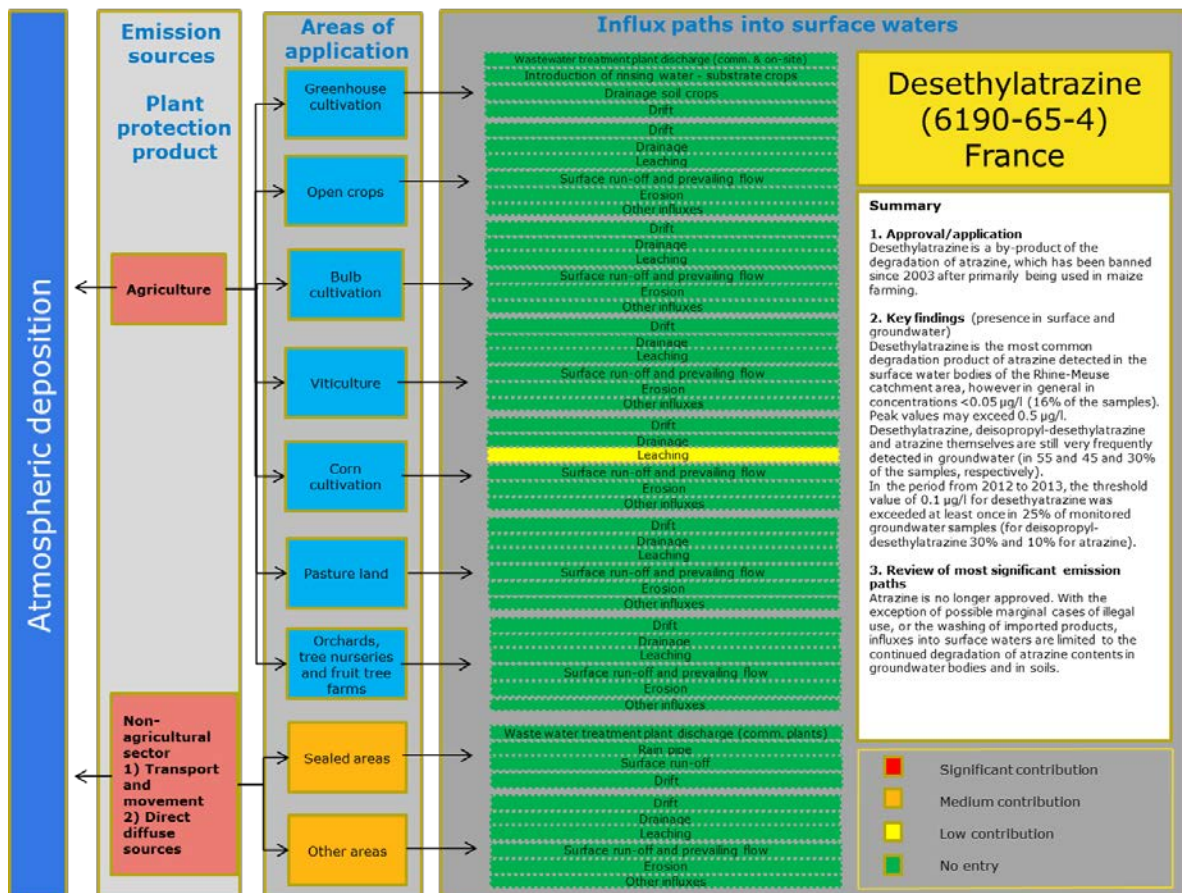
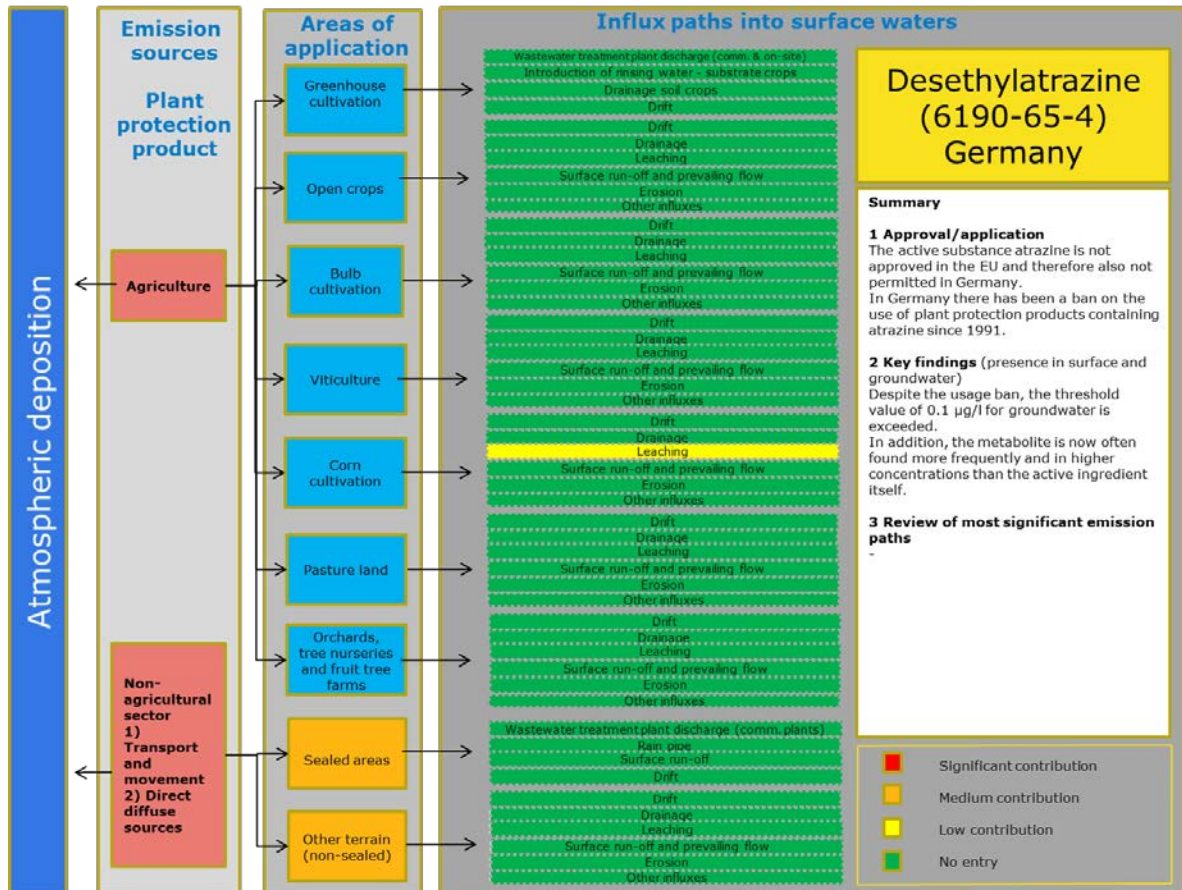

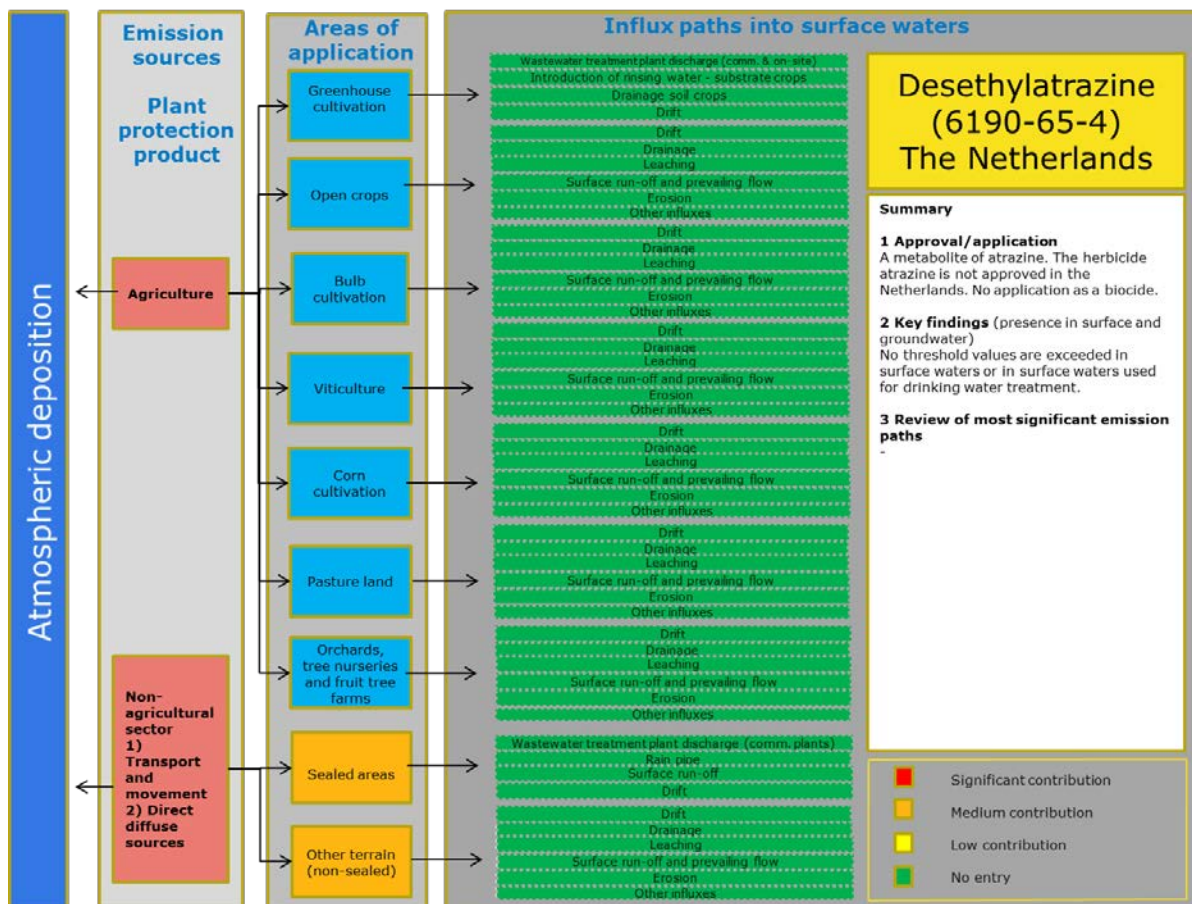
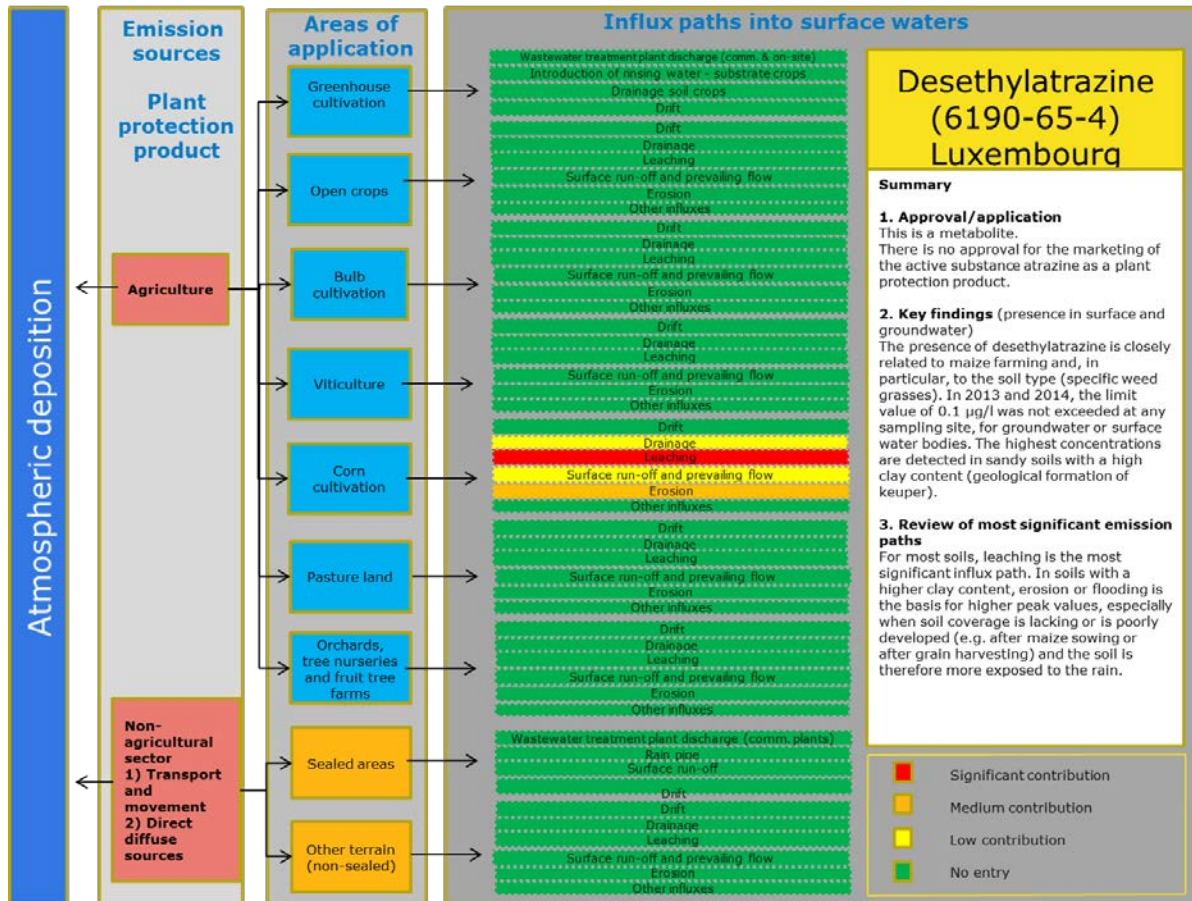

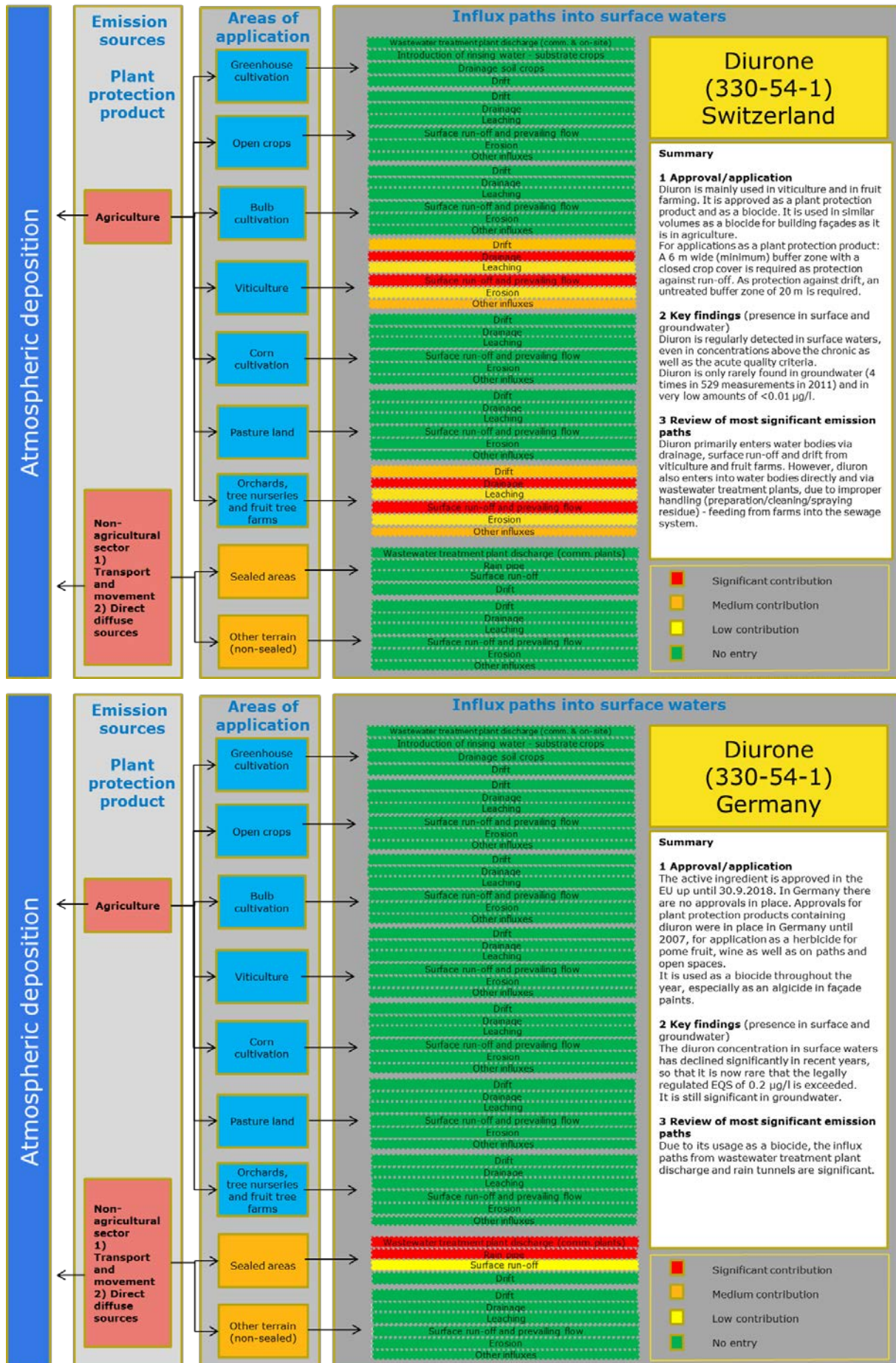

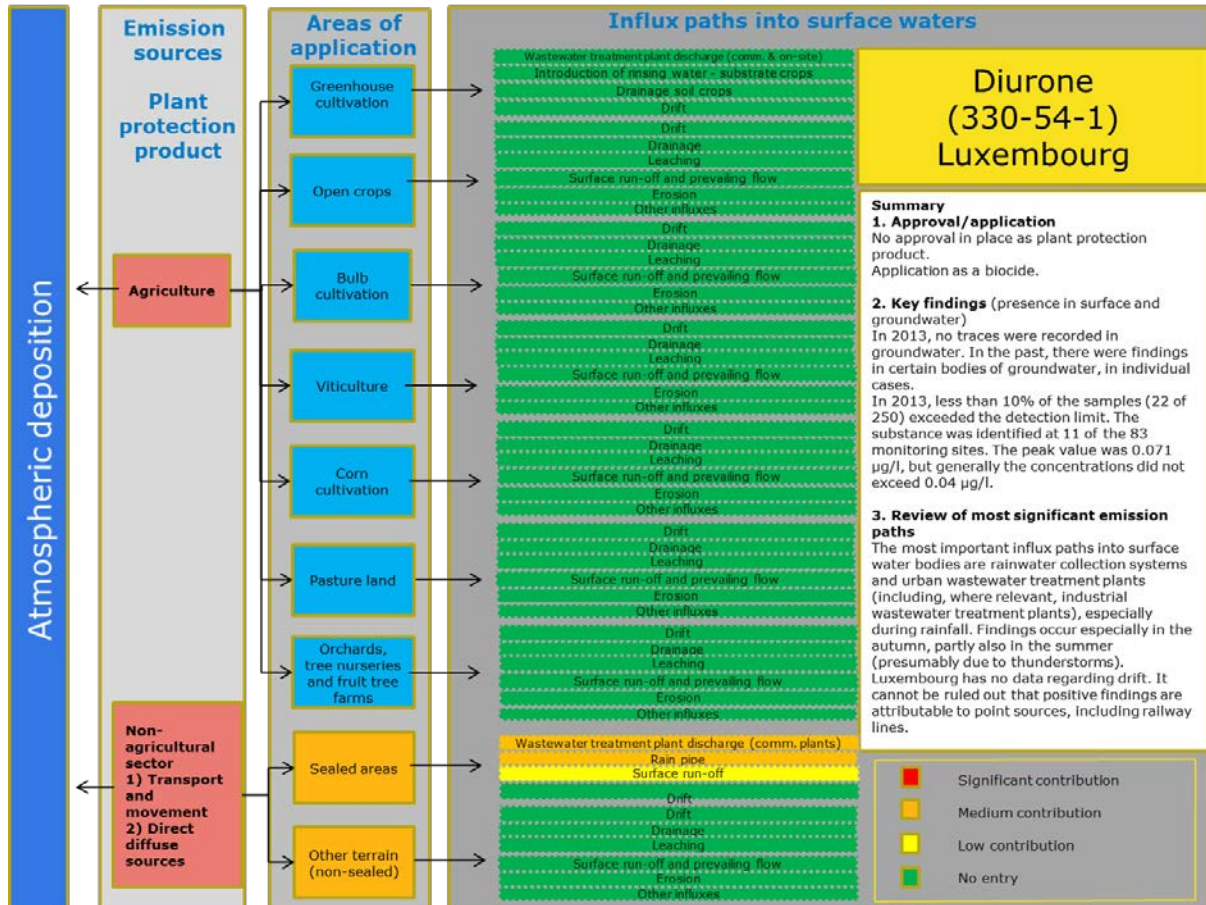
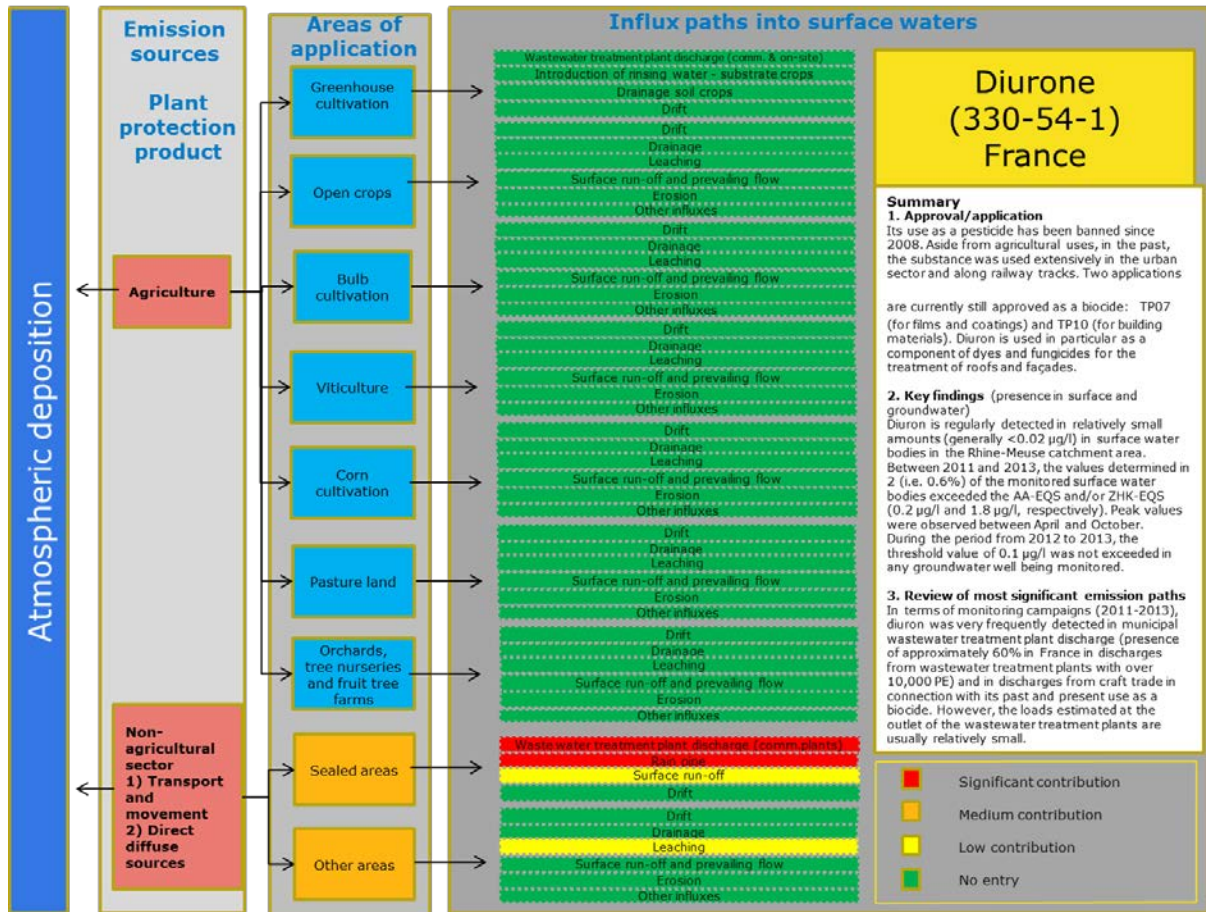

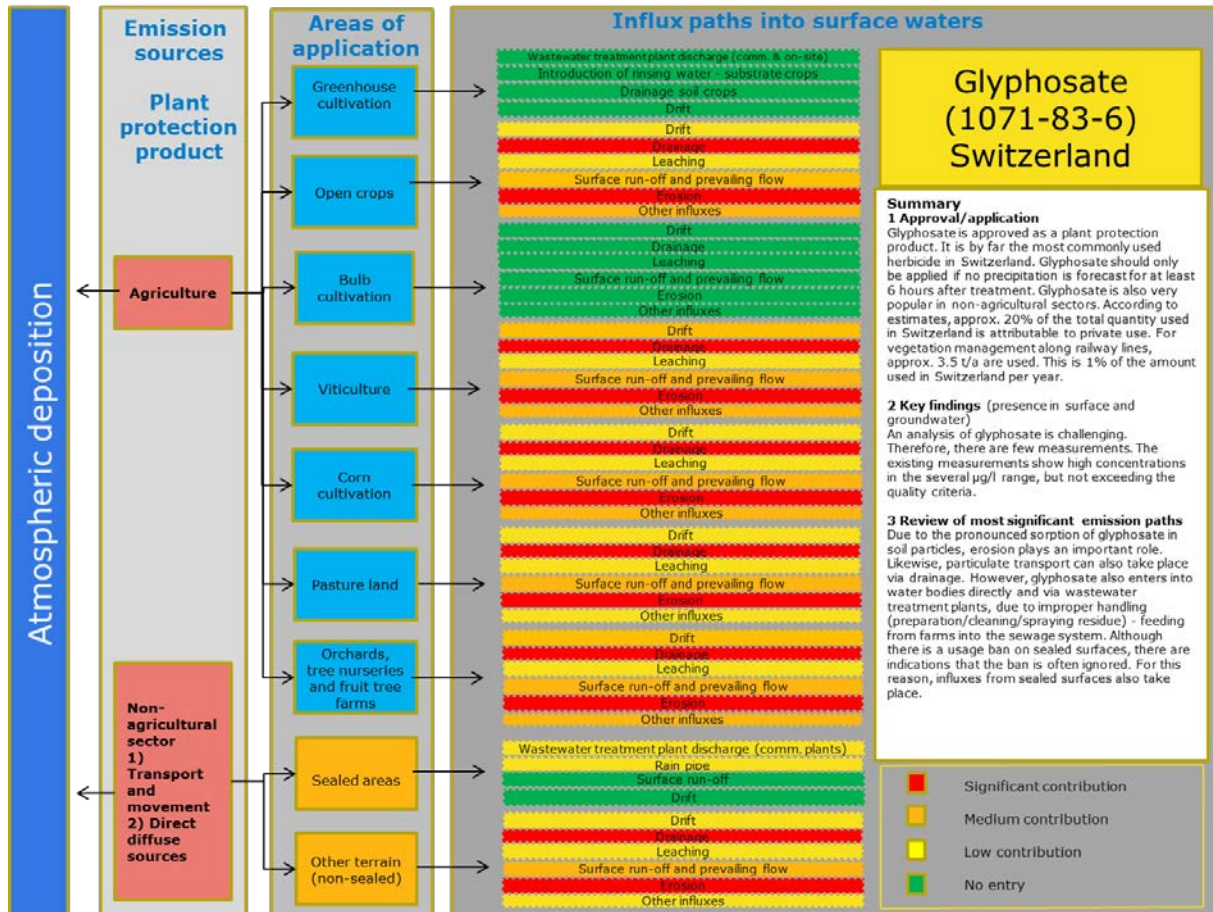
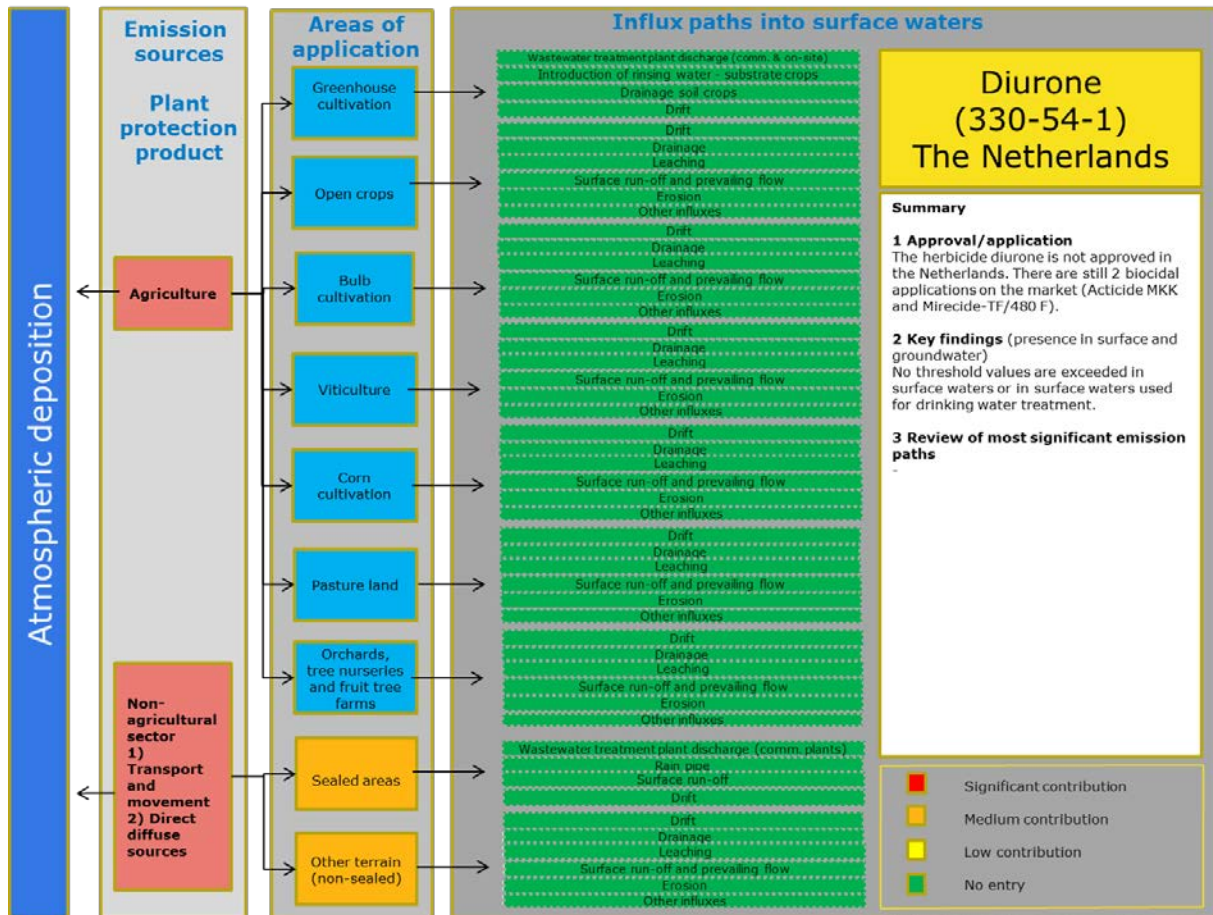

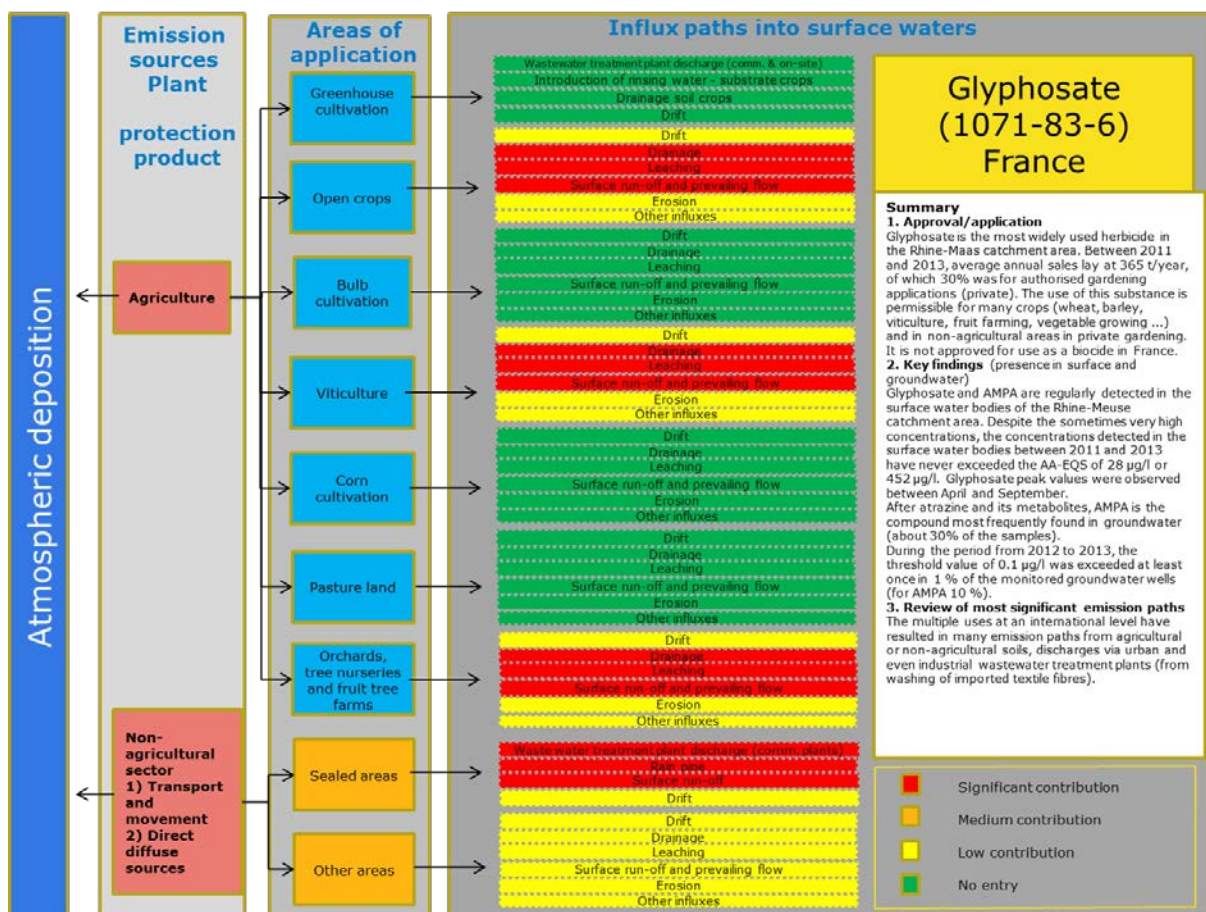
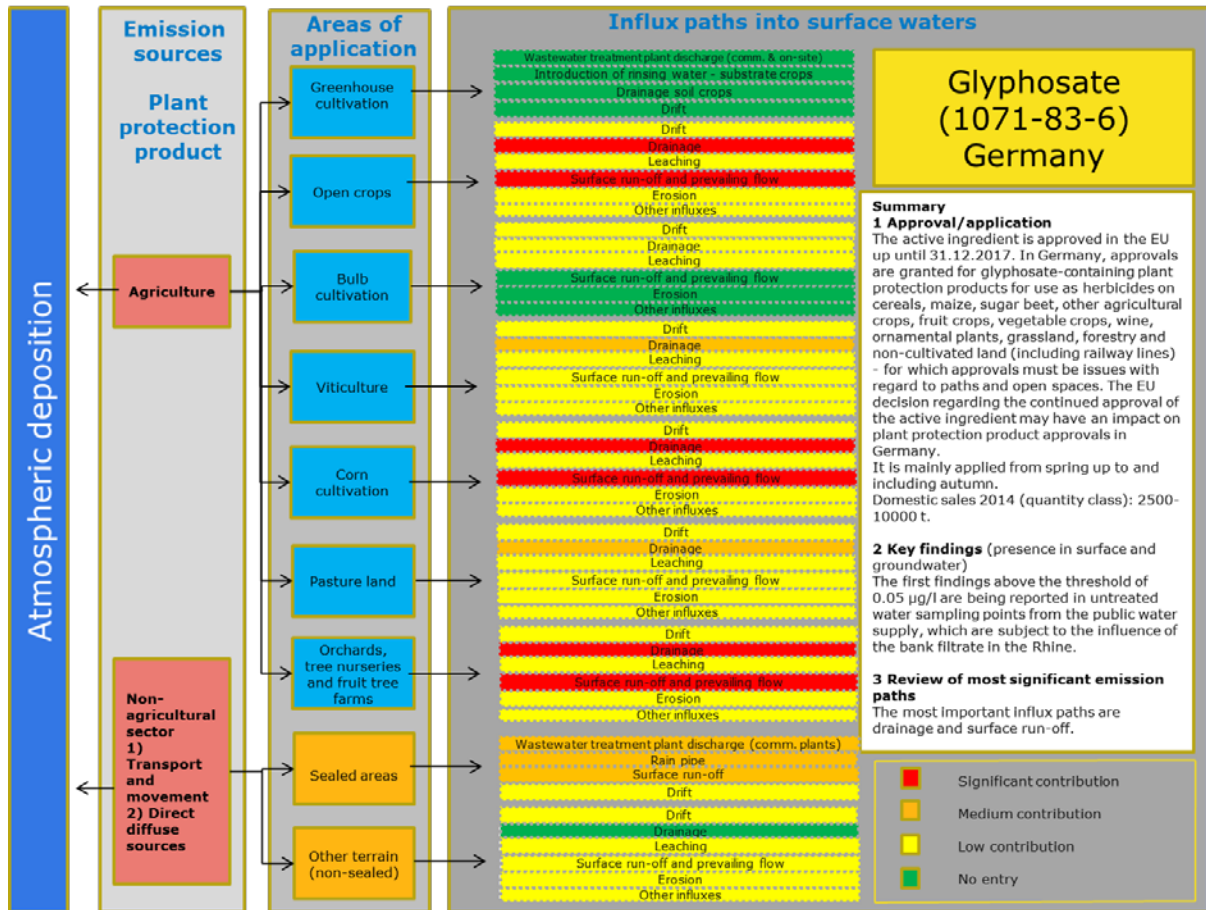

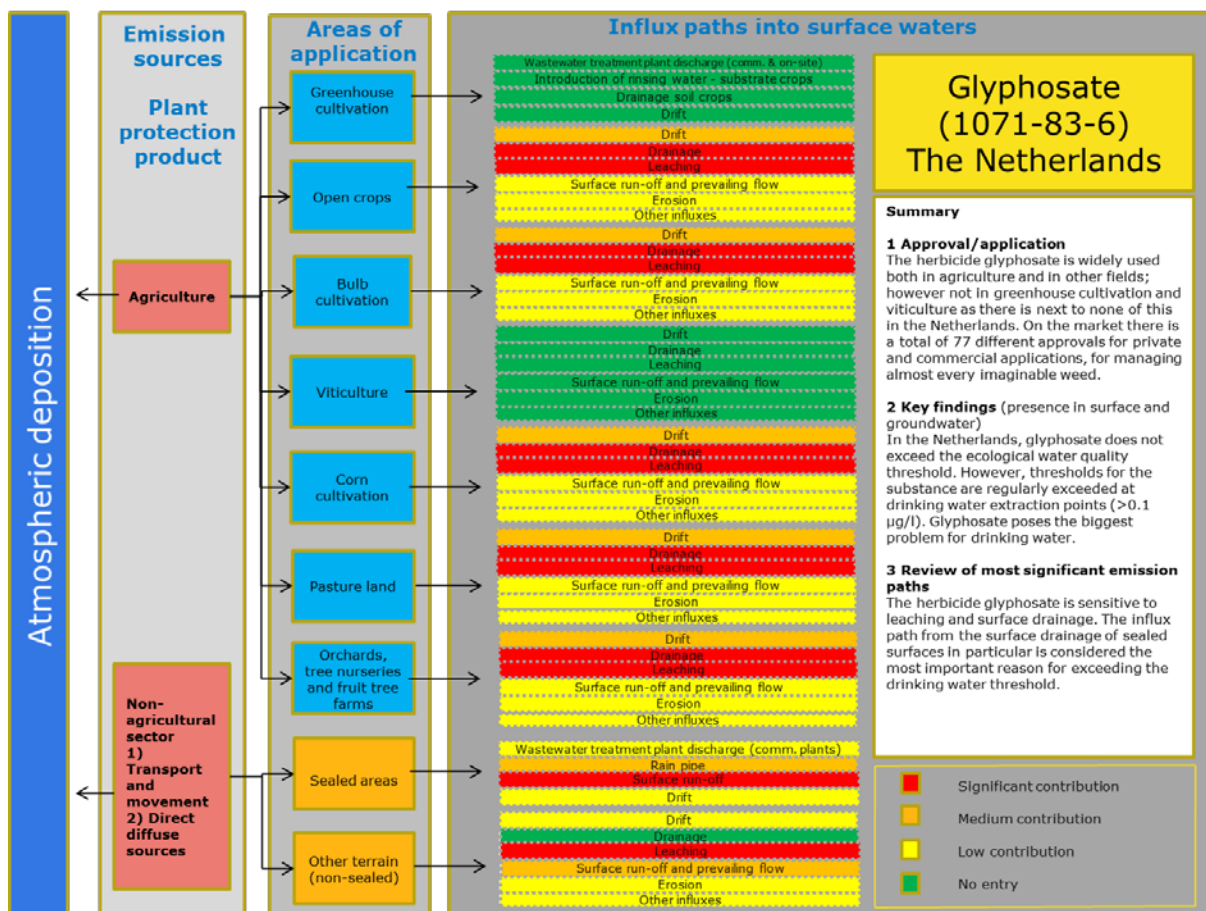
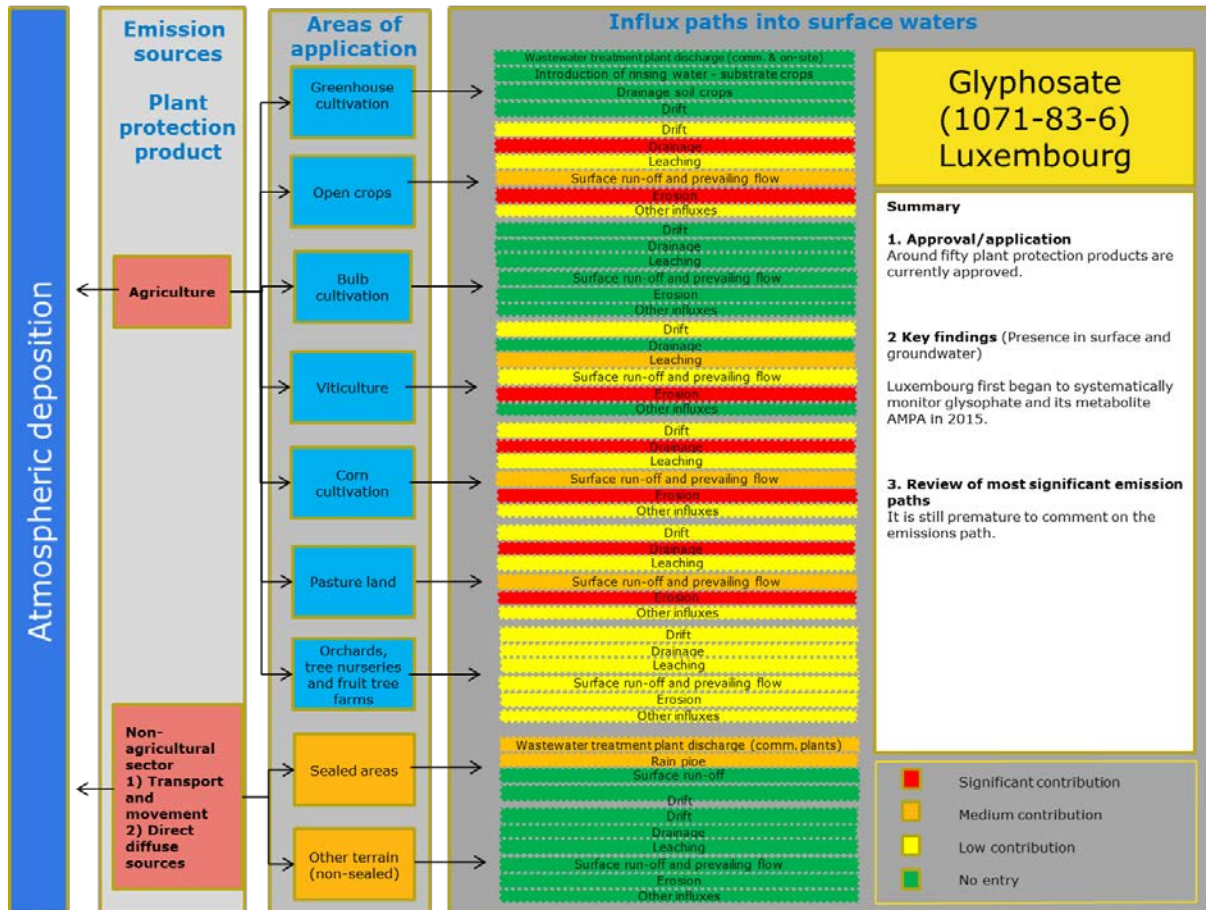

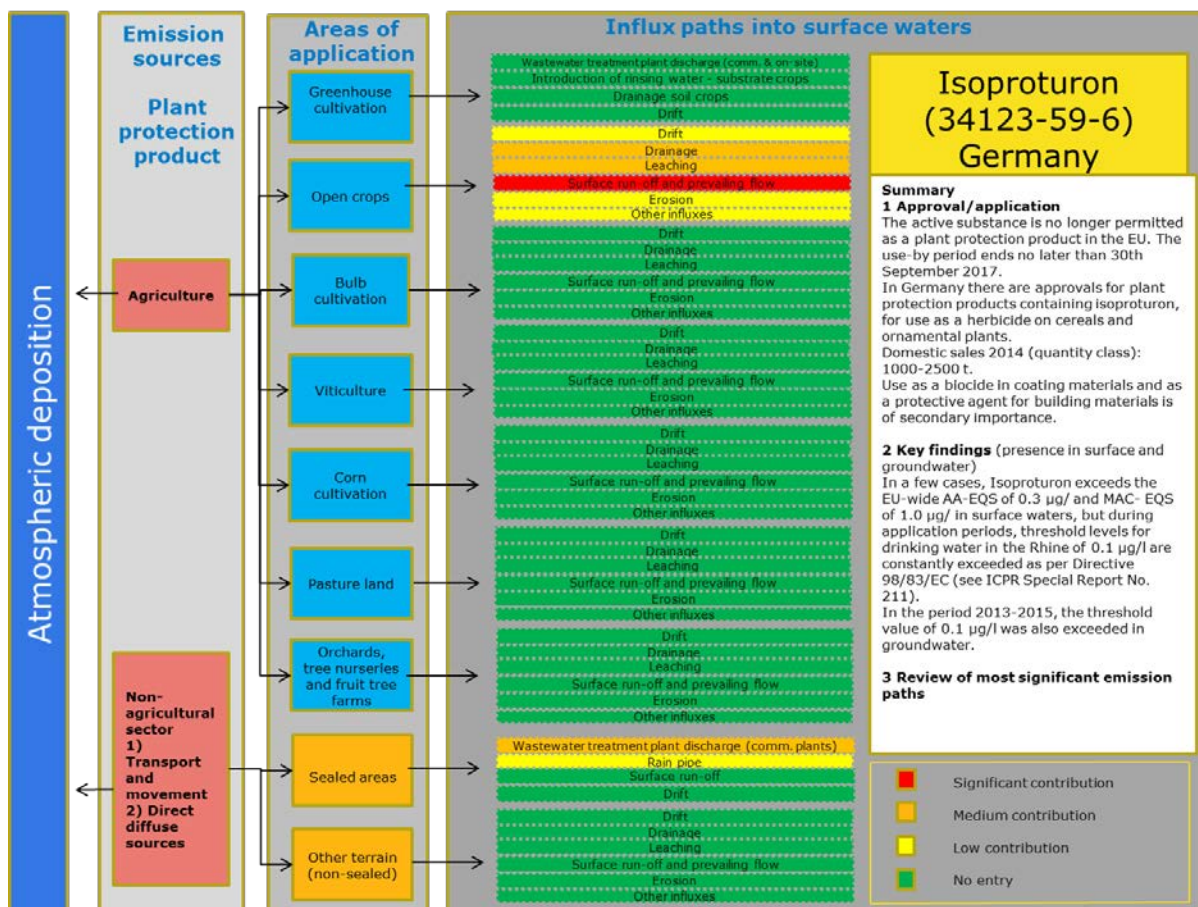
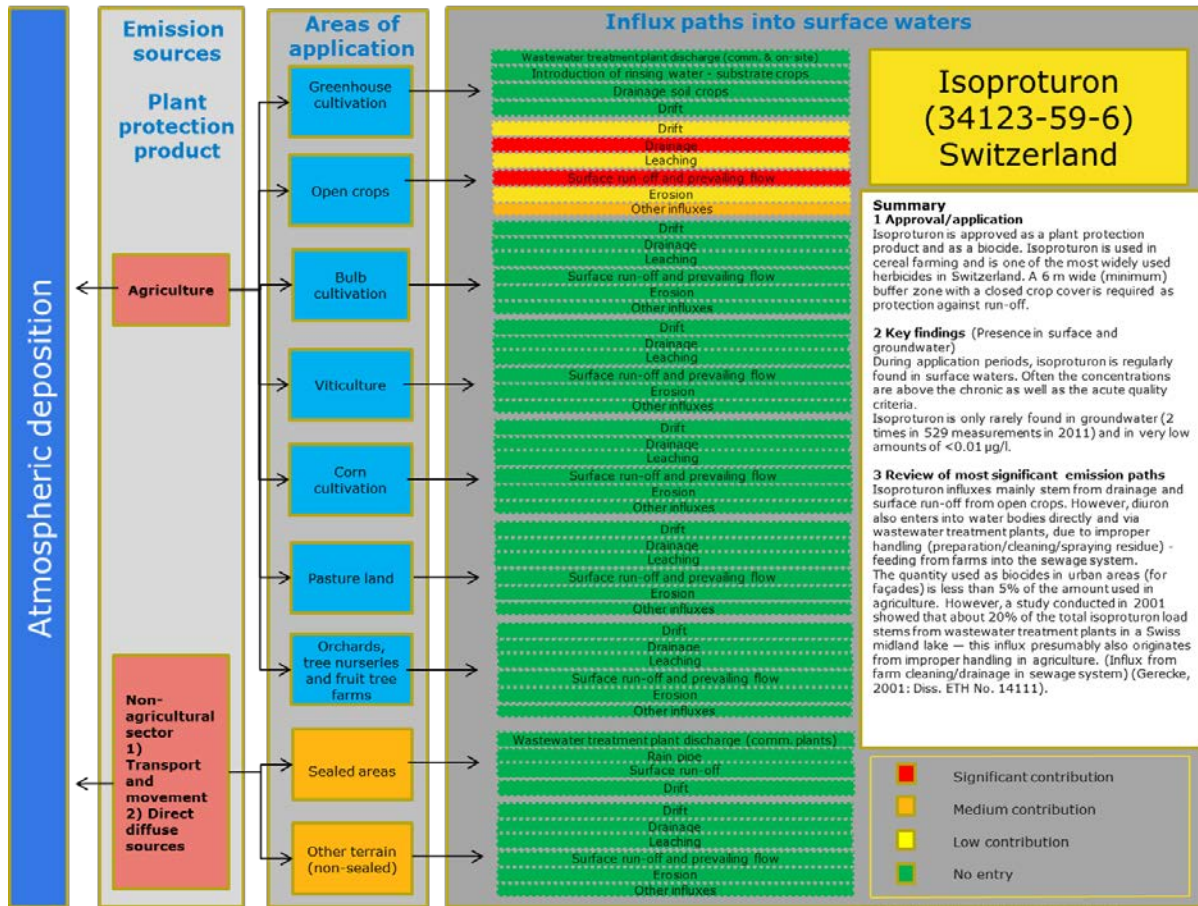

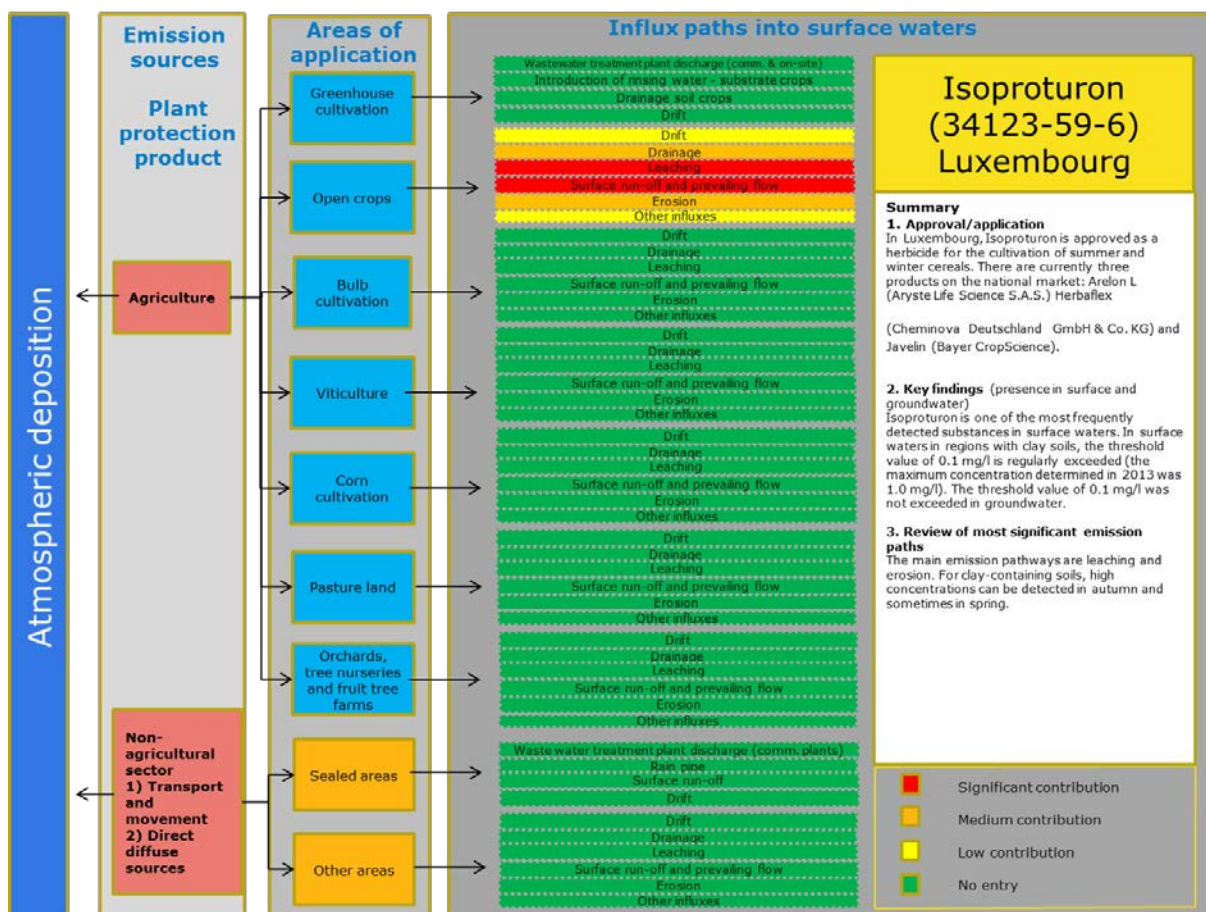
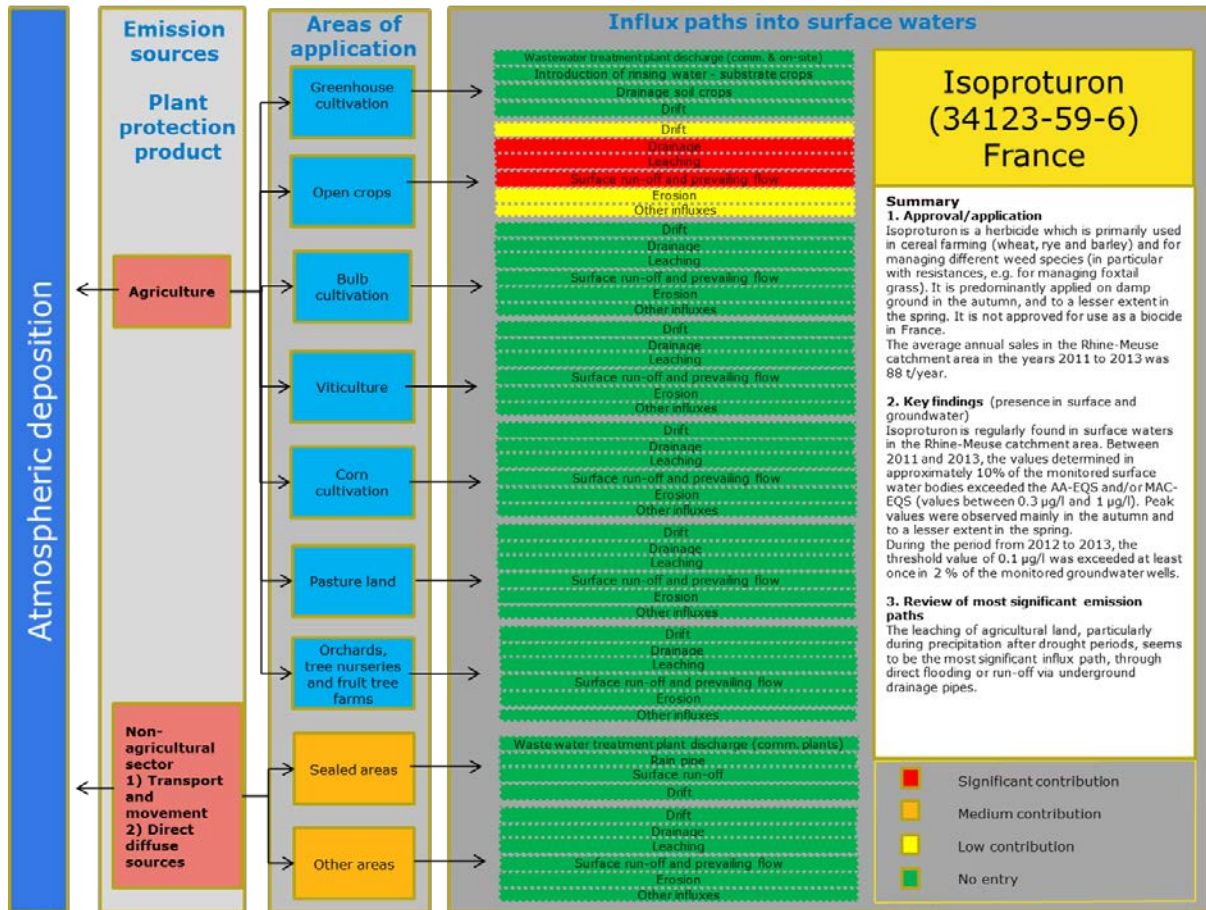

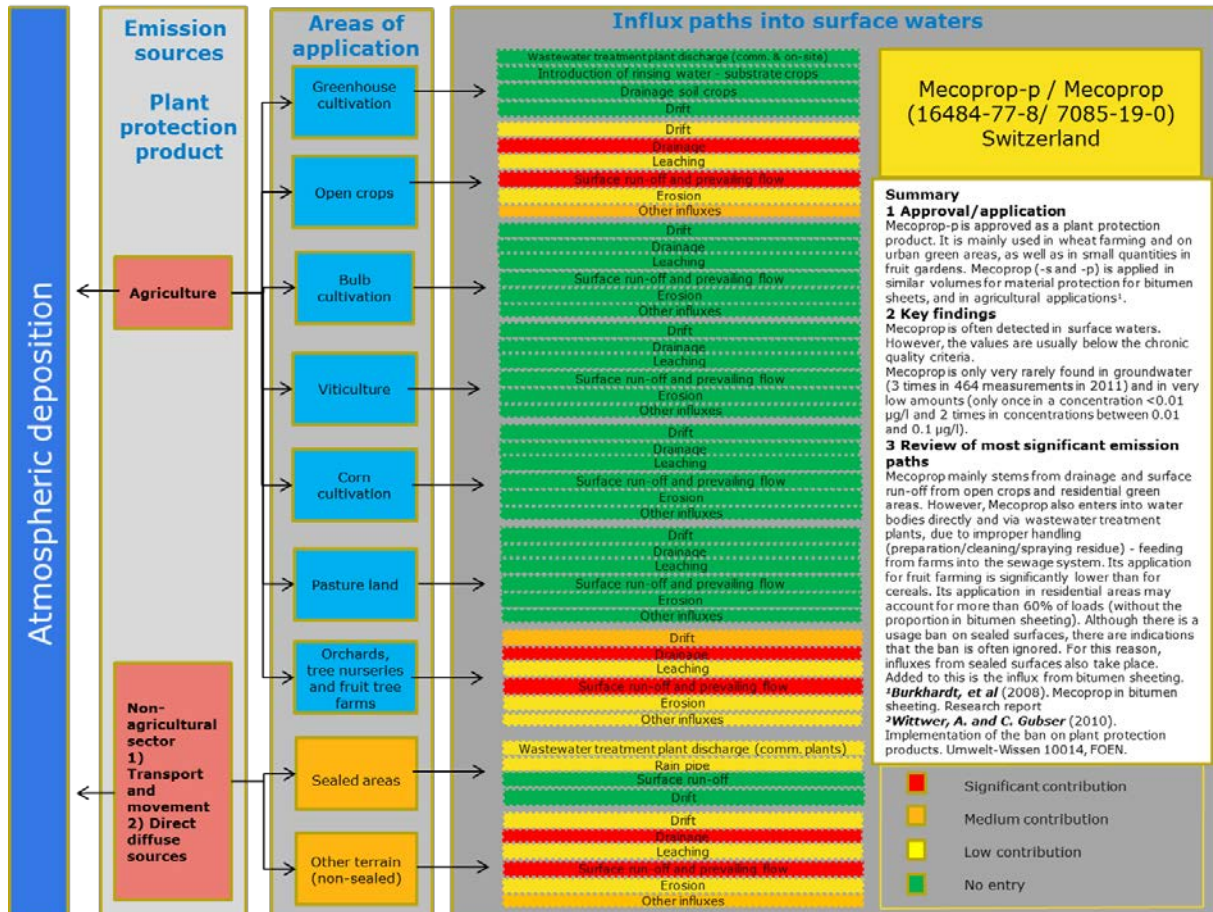
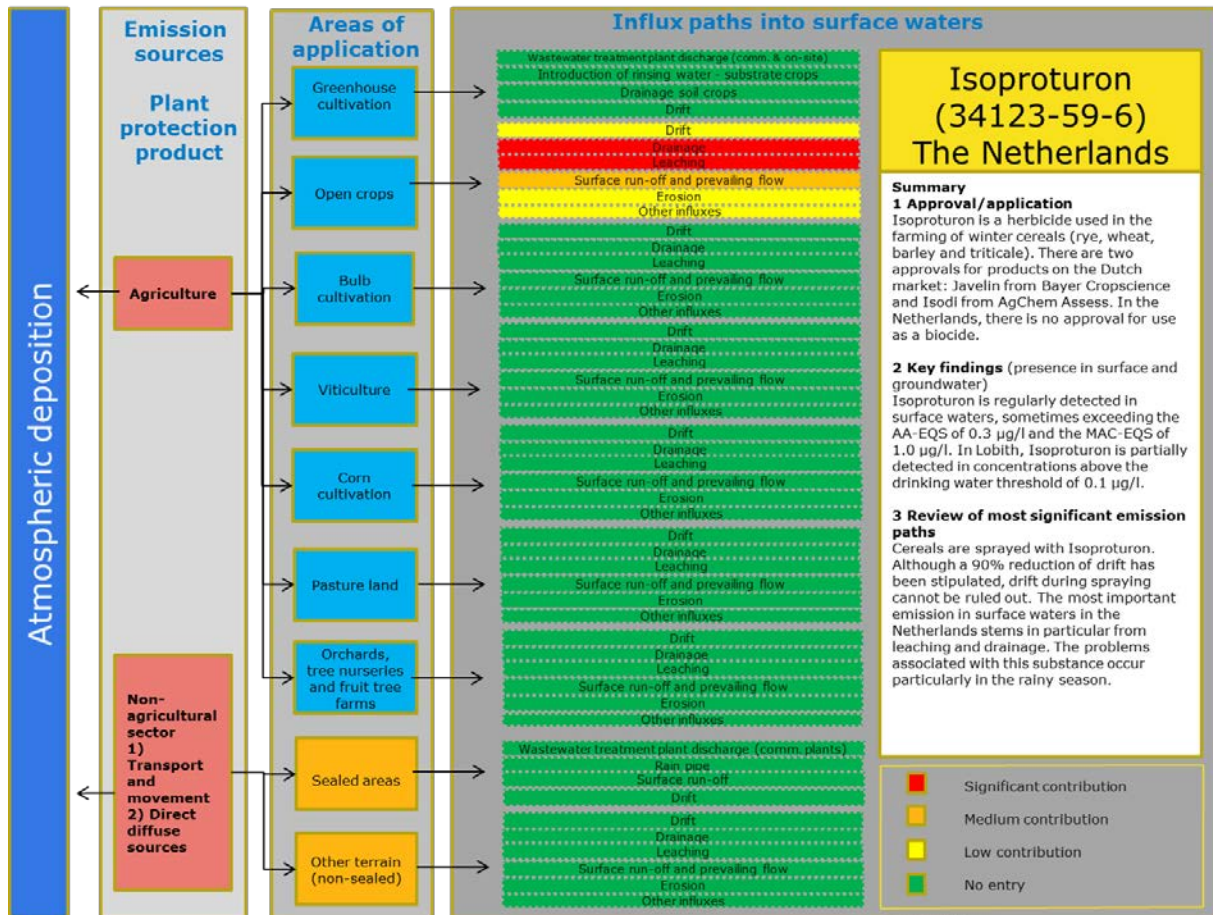

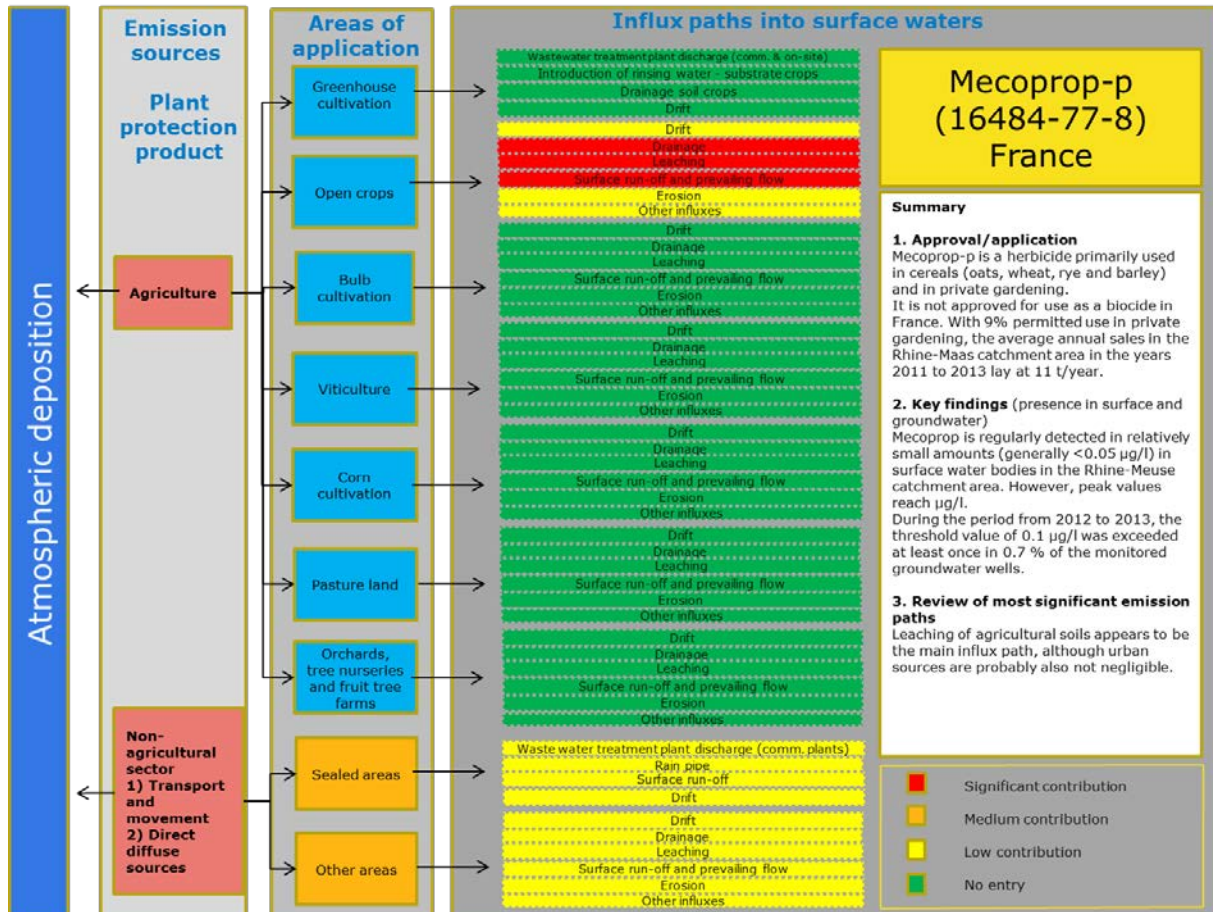
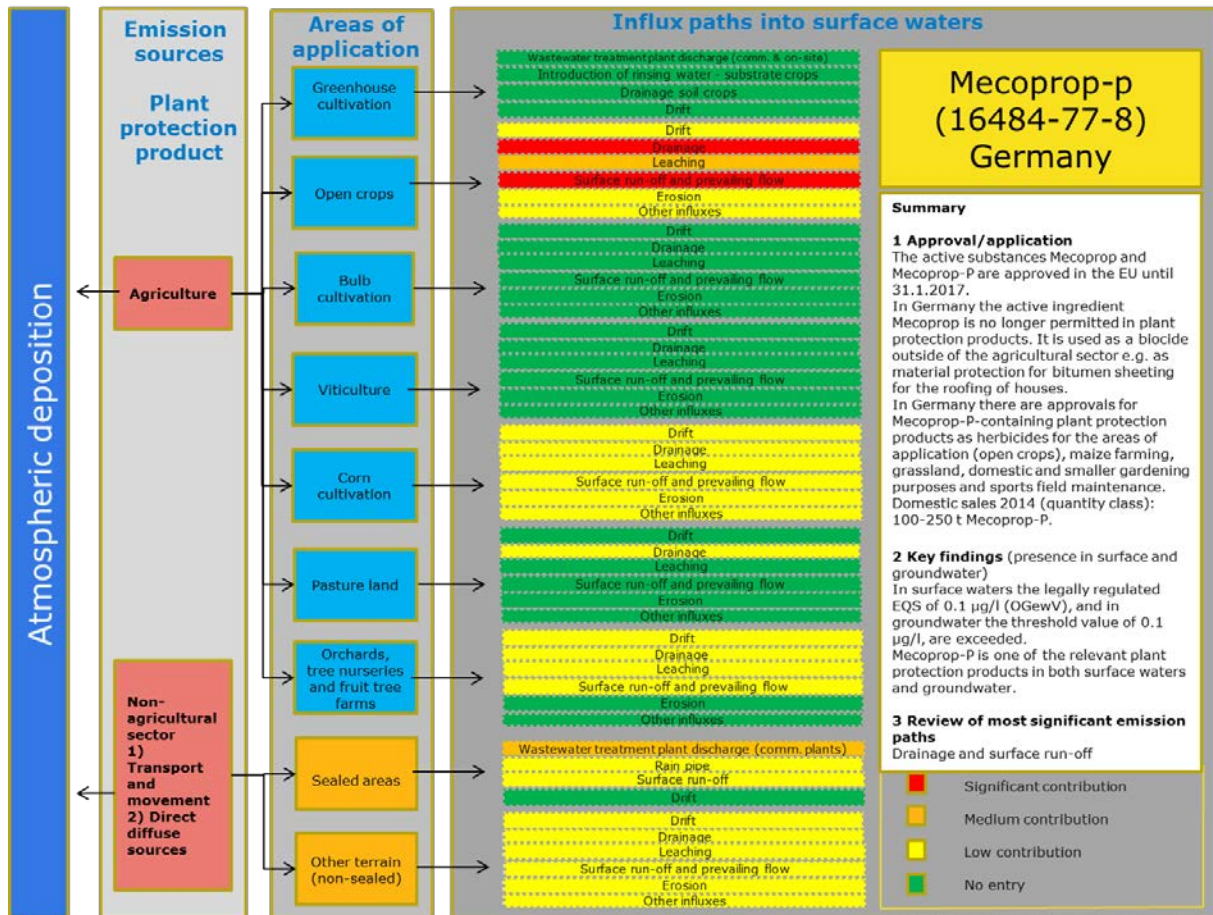

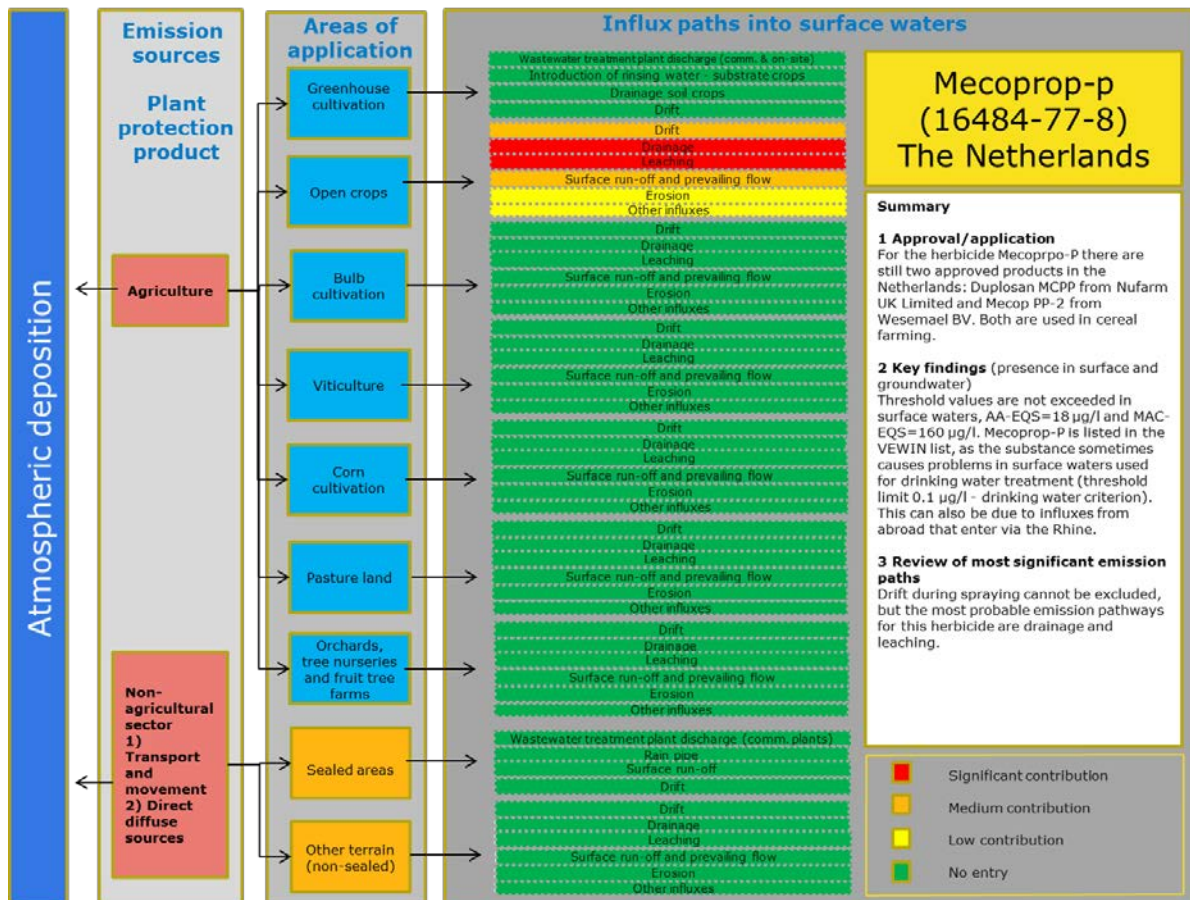
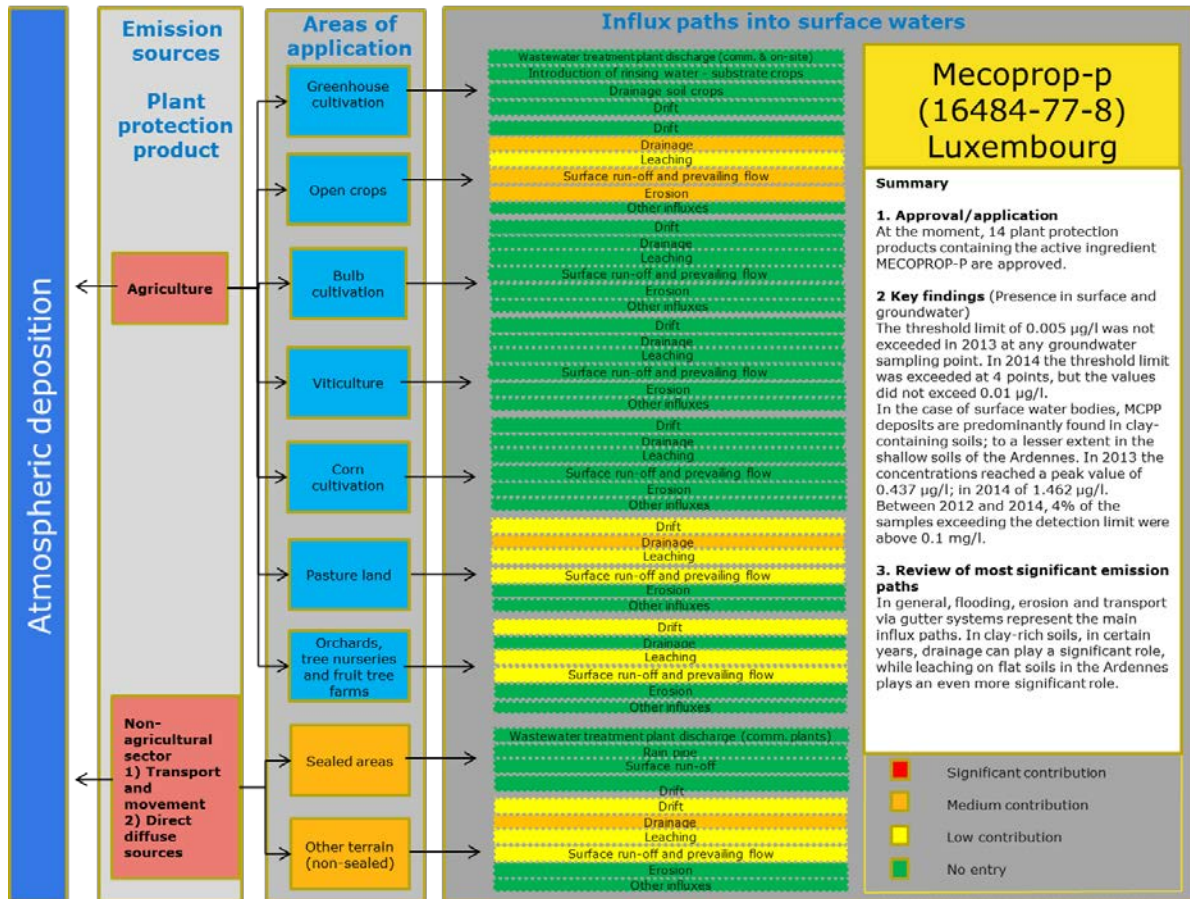

Appendix 2 National Measures and Projects

Measures

Switzerland

Agriculture

1. Fundamental state measures and provisions

- Application bans apply for plant protection products in nature reserves as well as in marshes and moors, hedgerows, forests and overground bodies of water (treatment of individual problematic plants with herbicides is possible in places).
- Distance from water of at least 3 m is obligatory. If the watercourse is excluded (deadline 31.12.2018), plant protection product ban in the entire watercourse (depending on the width of the section, 4.5 to >15 m distance from water).
- Ban on use of herbicides on and along roads, paths and squares (untreated conservation headlands of at least 50 cm between effective area and road is obligatory).
- It is obligatory to have a professional license for commercial applications (valid for an unlimited period, further training must be undertaken but is not checked).
- Aerial applications are only permitted with special approval.
- In order to strengthen the enforcement of the existing legal basis, guidelines for enforcement were drawn up. These elaborate upon the applicable laws, in particular that plant protection products may only be used when necessary, in the necessary dosage, and under suitable environmental conditions:
<http://www.bafu.admin.ch/publikationen/publikation/01719/index.html?lang=de>
- Spraying apparatus (PTO-driven or self-propelled) must be checked, but the frequency of the checks is only defined in the PEP (see below).
- Sprayers and spraying apparatus must be rinsed on the treated field. The equipment (PTO-driven or self-propelled, spray tanks > 400 l) must only be equipped with a rinse water tank in the PEP. Internal and external cleaning must also be carried out where possible on the field or in a specially designated, sealed space. In this case, the rinse water must feed into the liquid manure tank or be sent for special treatment.
- The Agriculture Act obliges the cantons to engage a Plant Protection Service. Tasks: Training, advising in the field, inspections of fields and the preparation of local forecasts regarding the development of harmful organisms. Often, private operators, who are also bound to commercial interests, have more of a presence than the cantonal Plant Protection Services.
- State research projects (not exhaustive): I) cultivation of resistant varieties (some successes recorded), II) development of alternatives to chemical plant protection (limited success), III) development of different forecast models for the warning systems, IV) development of methods to determine the exact dosage of plant protection product, V) research and development for improved application technology for plant protection products and VI) scientific expertise for the prevention of the introduction of harmful organisms.
- Plant protection products which are no longer used must be submitted to an established collection agent or returned to a collection point.

2. Additional measures within the framework of the Proof of Ecological Performance (PEP)

Around 98% of all Swiss farmers receive direct payments from the Federal Government. In order to receive this they must comply with the requirements of the PEP (<http://www.blw.admin.ch/themen/00006/00049/index.html?lang=de>). These also include a number of reduction measures for plant protection products:

- A minimum distance from water of at least 6 m is obligatory (the treatment of individual problematic plants with herbicides is permitted from a distance of 4 m).
- Limitations in terms of the selection of insecticides for cereal and potato farming, certain damage thresholds in some crops (pollen beetles, cereal leaf beetles, European corn borer, aphids).
- Minimum scope of biodiversity support areas, certain requirements for the encouragement of beneficial insects, adapted crop rotation and balanced fertilisation.
- PTO-driven or self-propelled spraying equipment must be tested by a recognised body at least every four years.
- Operability is tested once every four years (usage of plant protection products by self-declaration).
- Spot check laboratory analyses of the applied plant protection products (<100 for the whole of Switzerland) annually.
- PTO-driven or self-propelled splash and spraying equipment with a capacity > 400 l must be equipped with a rinse water tank for cleaning in the field.

3. Additional measures within the framework of organic farming

Of the approximately 98% of farmers who farm their land according to the PEP, approx. 10% additionally meet the requirements regarding organic farming (<http://www.blw.admin.ch/themen/00013/00085/00092/index.html?lang=de>). Synthetic plant protection products are not allowed in organic farming (copper is permitted, however, where there are no alternatives).

4. Other federal programmes

- Purchases of equipment are supported for the precise application of plant protection products (for example under-leaf spraying technology, anti-drift systems) which go further than the requirements of the PEP (duration of the programme is limited).
- Extensive production (Extensio programme):
 - No use of insecticides, fungicides and growth regulators.
 - In 2011, subsidies were paid for 70,000 hectares for the extensive production of cereals and rapeseed.
 - New subsidies are also being paid for the extensive production of sunflowers, field peas and broad beans.
- Regional programmes (projects 62a and 77a):
 - In accordance with Article 62a of the Water Protection Act, the Federal Government shall provide subsidies for cantonal projects for the prevention of flooding and leaching of substances, if this is necessary in order to meet requirements for water quality of water bodies, and the measures are not economically feasible. E.g. two industry-wide biobed systems were established, in which the rinsing water for spraying equipment is purified by means of biological processes.
 - Article 77a and b of the Agriculture Act prescribes support for regional and sector-specific projects to improve sustainability in the usage of natural resources (including the reduction of plant protection product use). Two projects aimed at the reduction of plant protection product usage are currently in the implementation phase.

Settlements

- Plant protection products may not be used: in protection zone S1 comprising groundwater wells and on railway lines in protection zone S2.
- Herbicides must not be used
 - a. on roofs and terraces;
 - b. in storage compounds;
 - c. on roads, paths and squares (treatment of individual problematic plants on national and cantonal roads with herbicide is possible);
 - d. on embankments and green belts along roads and railway lines (treatment of individual problematic plants on national and cantonal roads with herbicide is possible).(Item 1.1 Paragraph 2 Point c Appendix 2.5 Ordinance on Chemicals Risk Reduction)
- Awareness in the public is increased through informational campaigns:
<http://www.giftzwerg.ch/>
- There is, however, no training or advice for the Plant Protection Product Service regarding the use of plant protection products in the non-agricultural sector (parks, settlements), which is why bans are often ignored, knowingly or unknowingly.
- The entry of micropollutants (including plant protection products) into bodies of water via wastewater treatment plants should be reduced by 50% in the coming years through the expansion of approx. 100 wastewater treatment plants, to include a 4th treatment stage.

Austria

The measures used for the reduction of plant protection product influxes consist predominantly of a combination of provisions in legislation, financial incentives as well as the provision of advice and awareness campaigns. Based on the contents of the draft of the National Water Management Plan 2015, the essential elements can be summarised as follows:

Legislation:

Water Law Act (WRG 1959) – § 32 obligation regarding approvals: An impact which is deemed more than minor, and which indirectly or directly affects the quality of bodies of water is subject to approval, pursuant to § 32 Para. 1. The following is considered to be minor, unless proof is provided to the contrary: (inter alia) proper agricultural and forestry land use. In this context, use is considered 'proper' if it is carried out in compliance with the relevant legal provisions, in particular with regard to chemicals, plant protection products and fertilisers, sewage sludge, soil protection and forest treatment products, as well as particular water-related legislation (§ 32 Para. 8).

WRG 1959 – §§ 34ff: In areas with water abstraction, appropriate protection measures/precautionary measures serve to protect the abstraction of water from existing water wells and from planned or proposed water wells for the purpose of drinking water and utility water supplies. For this purpose, protected and closed areas are identified:

- Protected areas for the protection of water supply facilities pursuant to § 34 Para. 1 WRG 1959,
- Closed areas for the protection of general water provision pursuant to § 34 Para. 2 WRG 1959,
- Protected and closed areas to secure future water provision according to § 35 WRG 1959 and the

Plant Protection Product Act 2011, BGBl. [Federal Law Gazette] I No. 10/2011 last amended by the BGBl. I No. 189/2013: This Federal Act contains supplementary provisions for the implementation of Regulation (EC) No. 1107/2009 concerning the placing on the market of plant protection products. Furthermore, the provisions of the Directive 2009/128/EC for the sale of plant protection products are also taken into account.

Key objectives/measures are:

- The exclusive use (i.e. use or storage) of plant protection products which are authorised under the legal provisions.
- The intended and appropriate use of plant protection products. Compliance with the conditions and requirements laid down within the framework of approvals for the labelling of packaging of plant protection products is required.
- Compliance with the principles of good agricultural practice in plant protection, and wherever possible compliance with the principles of integrated plant protection.

For reasons of clarity, the "Principles on the use of plant protection products" are also included. For example, pursuant to § 13 of the Plant Protection Product Act 2011, the federal states have the option under certain conditions to impose restrictions or bans on plant protection products in certain areas, irrespective of the protected and closed areas contained in water-related legislation. The aim of the Plant Protection Act is to reinforce the prerequisites for minimised risk in the use of plant protection products within the context of the provision of approvals, the placing on the market, and the monitoring of plant protection products.

For the plant protection product active ingredients metazachlor and terbuthylazine, restrictions in terms of approvals for their usage in legislated water protection and closed areas were established e.g. due to the detected threshold value exceedances in groundwater (in particular by degradation products). In practice, this means that products with these active ingredients are to be provided with appropriate user instructions or application regulations.

National Action Plan concerning the application of plant protection products:

Within the framework of the implementation of the Directive 2009/128/EC and the Plant Protection Act 2011, nine federal state Action Plans were drawn up, taking into account the general principles of integrated plant protection, the principles of good plant protection practice and the application of precautionary approaches. These include measures (e.g. for strengthening advisory services, education and monitoring) which, inter alia, also support water protection. The federal state Action Plans were subsequently combined into a National Action Plan.

Financial incentives:

Cross-Compliance Regulation Regarding the Integrated Management and Monitoring System Within the Field of Direct Payments, Regarding the Upholding of Other Obligations (Cross-Compliance) and Other Horizontal Regulations (INVEKOS-CC-V 2010), BGBl. II No. 492/2009:

According to the EU Council Regulation No. 1782/2003, member states are obliged to establish minimum standards for good agricultural and environmental conditions. The corresponding provisions are contained in the national INVEKOS Implementation Ordinance 2008.

For plant protection, this includes:

- pursuant to the approval/authorisation of the plant protection product, application requirements regarding the indicators (e.g. crop/object, quantities/concentrations of expenditure, waiting period) must be complied with, as well as the requirements and conditions (e.g. required distance to surface waters, dangers to bees). These are visible on the labelling of commercial packaging or in the instructions for use.

- The preparation of spray mixtures, as well as the filling and cleaning of the containers for plant protection products, must be carried out in such a way as to prevent leakage of the spray mixture and seepage into the soil or penetration into surface waters, or entry into the sewer system.
- Where necessary, suitable protective equipment (protective clothing, protective goggles, respiratory protective masks, gloves and shoes) must be worn during application (as indicated on the commercial packaging or in the instructions for use). Instructions, such as for safe handling, should be followed according to the safety data sheet for the plant protection product.
- Requirements for appropriate storage

ÖPUL, the Austrian programme for the Promotion of Environmentally Friendly, Extensive, and Natural Habitat-friendly Agriculture:

The ÖPUL programme 2015 is implemented on the basis of the Council Regulation (EC) No. 1303/2013 of 17th December 2013, regarding support for rural development by the European Agricultural Fund for Rural Development (EAFRD). This programme contains a wide range of measures to support water protection, such as:

- abstaining from the use of chemical-synthetic plant protection products (organic farming, abstaining from yield-increasing resources on arable land and grassland);
- abstaining from the use of chemical-synthetic fungicides on cereal areas.

In addition, within the framework of the **Austrian Rural Development Program 2015-2020**, investment subsidies are offered for agricultural production, which aim to improve (inter alia) the environmental impact of production. The funding is aimed, amongst other things, at equipment for ground-level manure spreading, plant protection equipment and direct-sowing machines.

Training and raising awareness:

With regard to plant protection products, an exchange of information has been taking place between the federal government, federal states and plant protection product producers for years, in order to promote (in an advisory capacity) - in collaboration with the Chamber of Agriculture - the targeted use of plant protection products whilst avoiding a negative impact on groundwater.

In the federal states, consultancy activities are carried out with regard to the water-related use of plant protection products (e.g. soil and water protection advice, environmental advice, nitrate information services). These are generally carried out via the offices of the regional government and the Chamber of Agriculture.

Germany

National measures

Necessary measures for the reduction of diffuse pesticide influxes into bodies of water have a particular emphasis on agriculture. The 2009 and 2015 Management Plans contain the following measures - both implemented and planned - for the agricultural sector, which are also the basis for reporting to the EU.

Fundamental measures

Plant protection legislation

Plant protection legislation for the implementation of the EU guidelines in the field of crop protection encompasses the Plant Protection Act, the Plant Protection Application Ordinance and other implementation regulations governing the conditions of approval and application for plant protection products (e.g. requirements regarding distance from water bodies).

Shoreline margins (§ 39 Federal Water Act, provincial water laws of the federal states)
The German Federal Water Act (WHG) and the provincial water laws of the federal states (LWG) prescribe shoreline margins, which serve as "buffer strips" along waterways, to reduce substance influxes from diffuse sources (including plant protection products). Through their water laws, many countries in the Rhine catchment area make use of the possibility of derogation opened up by the WHG, regarding the regulation of the width of shoreline margins (inter alia). For example, there are shoreline margins that extend beyond the requirements of the WHG, with a width of 10 m in exterior areas (outside of settlements) in some federal states.

Additional measures

Agri-environment programmes, landscape management

The fundamental measures regarding plant protection products are prescribed for the federal states by means of comprehensive agri-environmental programmes (as an example from Baden-Württemberg: MEKA III: Reduction in Market Pressures and Protection of the Farmed Landscape or support programme for the agri-environment, climate protection and animal welfare (FAKT) - the successor programme of MEKA). Agricultural enterprises can receive subsidies, for example, for the following measures: environmentally-conscious operational management, abstaining from the use of chemical-synthetic production substances or extensive and environmentally-friendly plant production (e.g. reduced soil tillage, mulch sowing). The proposed measures must be carried out for a period of at least 5 years. In some federal states, the funding is linked to the requirement that no municipal sewage sludge may be spread throughout the enterprise area.

Since 2015, the EU's Common Agricultural Policy has also enabled farmers to meet their commitments to the creation of 5% ecological priority zones in the form of buffer margins along waterways. It is not yet possible to assess the extent to which this option is utilised in the federal states.

Essential cornerstones of both the agri-environment measures and the measures taken within the context of water protection cooperation are both the general advisory service for farmers regarding water protection, as well as specific advice on "measures for the reduction of the influxes of plant protection products from agriculture."

Since 2014, all non-private users must provide a certificate of competence in accordance with the Plant Protection Act. The agricultural administrative body therefore offers nationwide courses on the water-friendly use of plant protection products, which are now mandatory for farmers and other professional users.

France

Excerpt from the 10th Funding Programme (2013-2018) of the Agence de l'Eau Rhin-Meuse, Section 6.5 "Combating diffuse pollution of agricultural origin or in connection with the treatment of settlement areas"

1. Targeted funding to meet the requirements of the WFD in the Rhine-Maas catchment area

A two-level system has been set up which, on the one hand, takes account of eligibility criteria and, on the other, the prioritisation of these actions, whilst respecting the general principles of the programme:

- eligibility criteria as set out by the Agence de l'Eau, based on a **zone system**, which differentiates between **so-called "affected" areas**, in which the subsidising of "agricultural" products is generally possible and **so-called "unaffected" areas**, in which the same projects are generally not eligible for funding, except in special, explicitly justified situations. These areas are determined by the severity of their nitrate and pesticide loading.
- within the subsidy-eligible zones, priority is given to measures that focus on **campaigns in priority areas** (*drinking water protection areas, wetlands, other specific problem areas or areas with challenges*).

2. Subsidy areas

2.1. Support for projects "with high quality water compatible production chains"

The development of agricultural production chains, in particular of organic products or those which require few agricultural resources (*in particular extensive greenland production*), can provide lasting solutions for water management and the conservation of water resources. Aid in this area, which necessitates previous studies demonstrating the relevance of this approach, is provided in the form of support for development structures, the financing of market research, advertising campaigns, and also in the form of selective material investments.

2.2. Monitoring and involvement of regional authorities within the framework of partnership initiatives for resource conservation

Support for partnership initiatives "regional authorities - agricultural occupations" with the aim of developing suburban water protection production chains, opens up new perspectives. The support from the Agence is provided in the form of **assistance from regional authorities** (where applicable this may also be outside the community framework) and is proportionate to the expenditure incurred by these regional authorities in supporting agricultural producers and those placing these products on the market.

2.3. Sustainable resource protection through the approach regarding "land ownership"

There are a range of measures regarding "**land ownership**", which can be used within the context of a resource conservation project, and which also take into account the interests of those responsible on the ground. In this way, any study, or any project regarding the restructuring of landed property, any exchange of plots or other measures in this area can be subsidised if the significance of the project can be demonstrated within the context of reducing impairments of agricultural origin.

2.4. Optimal use of the existing and upcoming instruments of the Rural Development Program in France (RDP)

The 10th, two-stage programme will include **certain instruments of the Common Agricultural Policy (CAP)**:

- an **optimal or improved mobilisation of the current resources of the RDP**, in particular the agricultural and environmentally relevant measures, the "plant-environment" plan and the plan for the modernisation of livestock breeding buildings;
- mobilisation of the **new funds**, launched under the new agricultural programme ("successor" to the RDP).

2.5. Support for the reduction of transmissions by the establishment of buffer zones

A subsidy may be granted for campaigns aimed at restricting pollution by means of spatial planning measures, the establishment of buffer zones for "restoration measures"

and the reforestation of risk areas, embankments and hedges. The financing of these measures requires a prior study, which must emphasise the importance of these measures in particular.

2.6. Dealing with pesticides in non-agricultural areas

Regional authorities working towards a significant reduction or the cessation of the use of pesticides in the treatment of urban areas will receive financial support for their campaigns, provided that they are a component part of an umbrella programme.

Luxembourg

Measures for the reduction of plant protection products in Luxembourg

The installation of shoreline margins is the most frequently used measure for reducing plant protection product influxes. As foreseen in the Rural Development Plan (RDP) for the period 2007-2013, farmers have had to establish 3 m wide shoreline margins between cultivation areas and (more than 2 m wide) watercourses. This measure has been in force since 2008, and today more than 90% of farmers are participating.

Additional agricultural environmental measures, such as the conservation margins between fields and meadows, or the planting of hedges, have been in existence for more than 10 years within the framework of erosion protection; however they have not found widespread support among farmers. Within the scope of the new RDP time scale, plans have been put in place to create shoreline margins along all running water bodies and even non-permanent running water bodies. This, of course, has a considerable effect on the size of the cultivation area of the fields. However, due to the topographical conditions, this is already relatively small. It is therefore unlikely that these measures will be widely accepted by farmers.

In the region around the Upper Sûre lake, a reservoir which is an important source of drinking water production, the use of plant protection products in the primary protection area is prohibited. In the secondary protection area, the farmers must comply with 100 m wide buffer zones.

In general, the approvals for plant protection products determine the distances to flowing waters that must be in place during application. The current regulation of *cross-compliance* defines the general rules for the times of application for all approved products.

Efficient use of plant protection products

Thus far, the data regarding the usage of plant protection products is not very reliable. The sales statistics cannot be used because they are distorted due to the considerable proportion of cross-border trade with Germany, Belgium and France.

The law on plant protection products, which transposes Directive 2009/128/EC and Regulation 1107/2009 into Luxembourg law, has been in force since December 2012. An intended change to this law will prohibit the aerial application of plant protection products. In precisely defined regions and situations there will continue to be exemptions to this ban. In the vicinity of Natura 2000 sites or flowing water bodies, certain distances must be observed during application. This law also introduces the possibility of specific measures to reduce the impact on aquatic ecosystems and drinking water resources. These measures include (inter alia):

- Prioritisation of products with a low risk to the aquatic environment

- Prioritisation of application techniques that reduce spray drift
- Reduction or even prohibition of application along roads, railways and sealed surfaces
- Usage ban for plant protection products on public areas (sports facilities, playgrounds, school yards, public squares, cemeteries, ...) from January 2016.

The public consultation procedure within the framework of the revision of the first Action Plan for plant protection products entitled "Luxembourgian Programme for the Reduction of Plant Protection Products" has been completed.

After the ban on atrazine and dichlobenil, the concentrations of two important agents in the list of substances detected in bodies of water show a declining trend. For other systematically detected substances, there is now a ban in place (S-Metolachlor), or strong restrictions (Metazachlor) apply. Since the beginning of 2016 there has been a new monitoring network for surface and ground water. The monitoring of the resources used for the production of drinking water is dynamically re-evaluated in order to take into account the substances actually used in the extraction areas. In protected areas, more comprehensive restrictions apply to reduce or even prohibit the use of plant protection products which could pose a risk to the waters. In addition, the filling or cleaning of application vehicles is prohibited.

Training and advisory services for farmers will be further developed in order to better inform these users about the health and environmental impacts of the substances and to promote the efficient use of these products. In addition, more significant campaigns are being launched to increase public awareness and information provision, and to reduce the use of plant protection products in households.

The Netherlands

Reduction of influxes into surface water in the Netherlands

The measures for the reduction of plant protection products are regulated in the Netherlands through legislation and regulations. These measures are laid down in the Environmental Management Activities Ordinance. This means that buffer zones must be in place, which cannot be sprayed. Due to the fact that the fields are relatively small, these buffer zones are relatively narrow in relation to the surface waters in the Netherlands. In order to nevertheless achieve the required reduction, even with these narrow buffer zones, the focus lies on drift reduction by means of technical measures. Within the 14 meter zone along surface water bodies, drift-reducing nozzles are required, which enable reductions between the required minimum of 50%, and up to a maximum of 99%.

Farmland (vegetables)

- 1.5 meters from surface water during the application of a 50% drift-reducing measure in intensive farming (e.g. potatoes). If more influx-reducing measures are applied (75% =>), the buffer zone can be 1.0 m in certain cases.
- 25 cm for cereals, triticale and grass.
- 50 cm for all other arable crops

Flower bulbs

- A 1.5 meter zone around the surface water at 50% drift reduction.

Fruit farms and tree nurseries

- For down-sprayed crops, 1.5 meters.
- For trees, a buffer zone of at least 5 meters.

Fruit

- Large fruit such as apples and pears require a 1.5 meter buffer zone.
- Small fruit require a 0.5 m buffer zone.

In general, it is not permissible to spray embankments near surface waters. Inward spraying nozzles must be used. The height of the spray boom must not exceed 50 cm. Spraying may only take place at wind speeds below 5 m/s.

Sustainable use of pesticides

The Directive on the Sustainable Use of Pesticides (2009/128/EC) has been in force since 2009. The measures for sustainable use set out in this directive supplement the regulation 1107/2009/EC. The measures may be used to ensure the objectives of other community legislation, such as the Water Framework Directive (Directive 2000/60/EC). The implementation of the plant protection product policy for the period 1998-2010 has led to an 85% reduction in the calculated environmental impact on surface waters. Overall, the usage of pesticides has also declined slightly. However, these results are not sufficient to achieve the water quality objectives.

The following section describes how the influxes of plant protection products in surface waters in the Netherlands are to be further reduced in 2013-2023. These measures are defined in the Dutch National Action Plan on Sustainable Plant Protection and in a policy programme "Note on Healthy Growth and Sustainable Harvesting" (only available in Dutch at the Ministry of Economic Affairs). The key measures are listed below:

- Aerial spraying is prohibited. The Minister of Economic Affairs can grant an exceptional permit in emergency situations.
- The agricultural sectors have announced plans to further reduce the drift of plant protection products in surface water during spraying. The Environmental Management Activities Ordinance stipulates that spraying techniques with at least 75% drift-reduction are to be used (on the entire plot rather than in the 14 meter zone along waterways).
- 25 cm buffer zones are expanded to at least 50 cm.
- Due to the specific characteristics of greenhouse cultivation, measures in this area are aimed at reducing the use of plant protection products to a minimum, promoting the reuse of water and the reduction of residues in wastewater. In 2018, wastewater containing plant protection products must be treated with a minimum of a 95% cleaning capacity. The treatment can also be carried out in inter-company plants (up to 2021) or mobile processing plants. The necessity for treatment is set out in the activity ordinance for environmental management.

The authorisation holder for a product must create a plan for the reduction of its influx into waters, if monitoring data shows a plausible connection between threshold levels being exceeded and the application of a plant protection product. The authorisation holder is the key individual responsible for creating the plan for the reduction of the influx, as well as its management and implementation.

- The authorities shall carry out appropriate monitoring of the quality of the surface water in a specific monitoring network for plant protection products.
- There is a ban on the use of priority hazardous plant protection products in accordance with the WFD.
- Outside of the agricultural sector, the use of chemical plant protection products on sealed areas is to be banned from March 2016. The professional application of plant protection products is also prohibited on other sites from November 2017. Investigations are being conducted with regard to an application ban for private users.

Projects:

Switzerland

In accordance with Article 62a of the Water Protection Act, the Federal Government shall provide compensation for cantonal projects for the prevention of flooding and leaching of substances, if this is necessary in order to meet requirements for the water quality of water bodies, and the measures are not economically feasible. E.g. two industry-wide biobed systems were established, in which the rinsing water for spraying equipment is purified by means of biological processes.

Article 77a and b of the Agriculture Act provides support for regional and sector-specific projects to improve sustainability in the usage of natural resources (including the reduction of plant protection product use). Two projects for the reduction of plant protection product usage are currently in the implementation phase.

Within the framework of the implementation of the Action Plan for plant protection products, a number of projects have already been launched or are planned from 2017 onwards. These include research projects in the field of the reduction of leaching and run-off of plant protection products. In addition, the relevance of plant protection product influxes via hydraulic short circuits and possible reduction measures are being determined within the context of a research project.

Austria

In the summer of 2014, the "Future Crop Cultivation" initiative was launched. At the outset, relevant stakeholders were identified and initial discussions were held. Within the framework of several "World-Café" meetings, all stakeholders had the opportunity to actively participate in the strategy process. Thus the extensive knowledge of different parties as well as the different expectations regarding modern crop cultivation - from farmers, representatives of the economy, industry, consumers, science and non-profit organisations could be combined.

On the basis of these meetings, a 10 point programme was developed, drawing on expert judgements, which includes the key requirements of the stakeholders as well as a range of measures in the following thematic areas: The promotion of versatile crop rotation and an increase in biodiversity, the cultivation of breeds and varieties which are adapted to the location, soil-friendly production methods and purpose-oriented environmental monitoring, the development of integrated crop protection, the further reduction of the use of plant protection products, clear and transparent framework conditions for the approval of plant protection products, the linking of practice and research, educational campaigns for modern plant cultivation, increased public relations and better networking of all stakeholders.

The field of research represents a central and horizontal area within the strategy. For the new national research programme, a specific plant cultivation focus was established. A great deal of valuable knowledge has also been gathered outside of the research facilities — inter alia amongst federations and associations and from farmers. In order to make better use of this knowledge, within the framework of the European Innovation Partnerships (EIP) there has been an increased promotion of practical research projects since 2015.

On the subject of plant protection, substantive discussions were carried out, which led to a series of measures being undertaken. In order to create clearer framework conditions and increased transparency in the approval of plant protection products, a strict division of personnel in terms of those responsible for risk assessment in the Agency for Health and Food Safety (AGES) and for risk management at the Federal Office for Food Safety

(BAES) took place at the beginning of 2016. Furthermore, the trend demonstrating a sharp decline in the use of plant protection products is set to continue with various measures in place. The Plant Protection Warning Service - one of the most important instruments in integrated plant protection - has been reconfigured, and is now being co-financed under rural development. With an amendment to the Plant Protection Products Regulation, stricter rules for the supply of plant protection products in the domestic and private gardening sector came into force and for approvals relating to those which are potentially hazardous, transparent guidelines were published.

The implementation of the strategy is also to be continued in the coming years and should contribute to productive results in terms of solving the current problems in the Austrian agricultural sector. For example, the National Action Plan for the Sustainable Use of Plant Protection Products should be standardised across the country, the strategy for indicating any loopholes identified, and a roadmap for information and transparency regarding plant protection should be developed.

Germany

In Germany in January 2016, a 5 point programme for sustainable plant protection was published by the Federal Environment Agency (<https://www.umweltbundesamt.de/publikationen/5-punkte-programm-fuer-ein-nachhaltigen-0>). It shows that the use of chemical plant protection needs to be reduced, and measures are being taken towards more sustainable crop protection. There are also several projects in place at a local level in Germany. The Water Technology Center (TZW DVGW [German Technical and Scientific Association for Gas and Water]), for example, organises projects in groundwater areas that are contaminated with plant protection products. Here, the cooperation between the different parties, i.e. the competent authorities, the representatives of the plant protection product manufacturers and the affected water service suppliers, is of foremost significance.

Examples from the German federal state of Baden-Württemberg

Project regarding the "Identification of small-scale risk areas for the assessment and optimisation of WFD measures for the reduction of diffuse phosphate and plant protection products in surface waters: risk assessment for demarcated areas, taking into account the soil properties and surface run-off" of the Federal State Office for Geology Resources and Mining (LGRB) of the Freiburg Regional Board.

"Conservation Agriculture" project

From 2014, another project will be funded by the Ministry for the Rural Area and Consumer Protection of Baden-Württemberg (MLR). "Conservation Agriculture" with minimal soil cultivation (including strip-till) and optimised intercropping — a way to reduce the diffuse phosphate and plant protection products in surface waters and the nitrate influx into groundwater.

Examples from the German federal state of North Rhine-Westphalia

Development of an analysis and consultancy tool, the "Hotspot Manager":

Within the framework of this measure, a computer-assisted analysis and consulting tool (software system) for plant protection product-related consulting, information or analysis activity in NRW is currently being developed and tested. The aim is the model-based identification of hotspots based on the current situation in terms of agricultural practice (use, plant protection product application, etc.) and landscape situation as well as the calculation of the plant protection product risk potentials, taking into account pre-defined measures for risk reduction.

In principle, the system will be available to all federal states at a later date (details are still to be clarified, but this will be discussed in due course within the framework of the conference of the heads of the Plant Protection Services of the federal states; information: MKULNV [Ministry for Climate Protection, Environment, Agriculture, Conservation and Consumer Protection of the State of North Rhine-Westphalia] NRW).

France

In France an Action Plan on plant protection products, especially regarding isoproturon, has been launched. This Action Plan includes the following steps: The establishment of a special working group in which all agricultural sectors are represented, under the direction of the Lorraine Chamber of Agriculture; the regular review of sales figures and consultations provided; a standardised joint memo regarding the limitation of isoproturon use in specialist papers and articles in the Lorraine agricultural press - in order to reach all farmers in Lorraine; the organisation of a seminar (11.02.2016) for all agricultural consultants with a view to exchanging information regarding progress in research and development in the area of "plant protection products and transfers", and developing and cultivating a common culture; the INTERREG project referred to in section 4.4, regarding the Moselle area.

Luxembourg

In Luxembourg, a 5-year (2015-2019) research project was launched for sustainable water and soil protection, as well as for the promotion of greater biodiversity (<http://www.lwk.lu/pflanzenbauberatung/effo-effiziente-fruchtfolgen-und-wasserschutz>). Due to more efficient crop rotations, loading from plant protection product residues should be reduced.

The Netherlands

For the Netherlands, the report on healthy cultivation and sustainable harvest, as referred to in section 4.3, and the National Action Plan (NAP) are both valid. The NAP contains statutory requirements, and the additional report extends beyond these. At present, additional measures are being considered within the framework of the delta approach to water quality and fresh water. In the following, three specific projects are described which are aimed at the prevention of water pollution by plant protection products, the Emission Limitation Toolbox, the Survey of Farmyard Emissions and Netherlands TOPPS.

Emission Limitation Toolbox

Nefyto, the Dutch Union of Water Associations, Agrodis and LTO Nederland worked in collaboration here. They developed the Emission Limitation Toolbox. With this toolbox, the parties concerned hope to make farmers more conscious of the influx pathways of their establishments, and to offer them possibilities for action in order to reduce the influxes.

The Emission Limitation Toolbox consists of 17 different information cards with practical measures for reducing the influxes of plant protection products into surface waters. Plant protection product distributors and supervisors from the water associations distribute the toolbox cards to farmers during visits to their holdings. The representatives visiting the farms can indicate improvements that could be made, and can now offer practical alternatives using the toolbox cards. LTO Noord, ZLTO and LLTB distribute the toolbox cards at events.

Survey of Farmyard Emissions

By completing the Survey of Farmyard Emissions at www.erfemissiescan.nl farmers can easily see where there are (more) ways to further reduce the contamination of surface water. They answer questions about filling spraying apparatus, interior and exterior cleaning, shutting off the spraying equipment and the farmyard set-up. As a result, they are shown which of these activities result in influxes into the surface water. In addition, the survey contains information on the legislation regarding farmyard discharges and practical information on possible measures to reduce farmyard discharges.

The Survey of Farmyard Emissions was developed by CLM Onderzoek en Advies and Broos Water at the request of LTO Nederland, the Union of Water Associations, Agrodis and Nefyto. These organisations began the campaign in 2014 with the Emission Limitation Toolbox (toolboxwater.nl), which includes the Survey of Farmyard Emissions. The development of the Survey of Farmyard Emissions was made feasible through financial support from TOPPS, and has already been used by 500 farms.

The current Survey of Farmyard Emissions focuses in particular on arable farming. Currently, funding is being sought to expand the survey to include emissions paths specific to bulb crops, fruit farming and plant cultivation.

Netherlands TOPPS

Nefyto and the European specialist association ECPA launched the EU project TOPPS in June 2015, in the Netherlands. TOPPS is the abbreviation for Train Operators to Promote Best Practices and Sustainability, a project that has been running in different EU member states for several years. Over the years, TOPPS has led to a number of Best Management Practices (BMP). These BMPs are the result of studies and practical insights involving scientists and cultivators.

The Netherlands TOPPS project follows projects such as Schone Bronnen and Water ABC, and focuses on limiting plant protection product influxes into surface water. Several stakeholders are involved in the TOPPS project, which runs until the end of 2017.

The Netherlands TOPPS consists of two sub-projects. The first sub-project is the Survey of Farmyard Emissions, which was developed in 2014. The other concerns the surface run-off from plots. For the sub-project regarding surface run-off from plots, a demo project has begun in Kollumerwaard, in cooperation with LTO Noord. Here, BMPs developed by the farmers themselves are tested, measured and demonstrated. One of these BMPs is the introduction of soil embankments in the plots, parallel to ditches. These embankments are then compartmented, with the result of less run-off from the plot.